



July 1, 2005  
Lit. No. 28270, Rev. 00

# MECHANIC'S GUIDE



**SNOWPLOWS**  
Featuring the  
**FloStat® Hydraulic System &  
Isolation Module Light System**

**⚠ CAUTION**

Read this manual before servicing the snowplow.



# TABLE OF CONTENTS

Introduction .....	4	Controls .....	25
Preface .....	4	General Information .....	25
Required Tools .....	4	Adapter Cable (PN 66760K) .....	25
Available Service Items .....	4	CabCommand Hand-Held Control (9 Button) .....	26
Safety Information .....	5	Joystick Control .....	28
System Overview .....	8	CabCommand Hand-Held Control (6 Button) .....	30
Blade, T-Frame & Lift Assemblies .....	8	Fuse Replacement .....	32
Snowplow Components .....	8	Terminal Removal Tool .....	33
Securing Pivot Bar to T-Frame .....	8	Replacing Terminals .....	33
Pivot Plates .....	9	14-Pin Connector Pin Assignments .....	33
Initial Stand Shoe Setup .....	10	Theory of Operation .....	34
Stand Shoe Adjustment .....	10	Snowplow Headlamps .....	34
Stacking Stop Configuration .....	11	Snowplow Daytime Running Lights .....	34
T-Frame Leveling Adjustment .....	12	Snowplow Hydraulics .....	34
Blade Spring Replacement Tool (PN 20043) .....	13	Electrical & Hydraulic Schematics .....	35
Lift Arm & Lift Ram Installation .....	14	Electrical Schematic .....	36
Headlamp Beam Aiming .....	15	Hydraulic Schematic .....	37
Vehicle Lighting Check .....	15	Raise .....	38
Hydraulic .....	16	Lower .....	40
FloStat® Hydraulic System .....	16	Angle Right .....	42
Specifications .....	16	Angle Left .....	44
Hydraulic Fitting and Hose Installation .....	17	Vee .....	46
Hose Routing and Fitting Orientation .....	18	Scoop .....	48
Assembly .....	19	Right Retract .....	50
Cartridge Valves .....	20	Right Extend .....	52
Relief Valves .....	21	Left Retract .....	54
Pilot-Operated Check Valves .....	22	Left Extend .....	56
Ram Seal Installation .....	23	Hold in Raised Position .....	58
Electrical .....	24	Striking An Object While Plowing .....	59
Wiring .....	24	High Beam Headlamps with Snowplow Connected to Vehicle .....	61
		Low Beam Headlamps with Snowplow Connected to Vehicle .....	62
		Troubleshooting Guide .....	63

# INTRODUCTION

---

## PREFACE

This guide has been prepared to assist the trained mechanic in the service of WESTERN® snowplows. It also provides safety information and recommendations. We urge all mechanics to read this manual carefully before attempting to service the WESTERN snowplow equipment covered by this guide.

Service of your WESTERN snowplow equipment is best performed by your local Western Products outlet. They know your snowplow best and are interested in your complete satisfaction.

## REQUIRED TOOLS

- Long/Slender Needle Nose Pliers
- Flat Screwdriver
- 12V Test Light
- Torque Wrench (in-lb)
- Allen Wrench Set
- Combination Wrenches: 3/8", 7/16" (2), 1/2", 11/16", 3/4", 7/8", 1-1/16", and 1-1/8"
- 1/4" Drive Ratchet, 6" ext., 5/16", 1/4" and 3/8" socket
- 3/8" Drive Ratchet, 1/2" and 9/16" Sockets
- 1/2" Drive Ratchet, Deep Sockets: 11/16", 7/8", 1-1/16", 1-1/8"
- Digital Volt/Ohmmeter
- Pressure Test Kit
- Flashlight
- Pick Set
- Hammer
- Pencil Magnet
- #20 TORX® Driver
- 10- and 15-amp Automotive Blade-Type Fuses

## AVAILABLE SERVICE ITEMS

- Motor Bearing Sleeve Repair Kit: PN 64589
- Isolation Module Tester: PN 64431
- Pressure Test Kit: PN 56679
- MVP® Electrical Tester: PN 63145
- Electrical Tester Isolation Module Adapter: PN 64427
- Spring Removal Tool: PN 20043
- Test Harness: PN 28957

# SAFETY INFORMATION

## SAFETY DEFINITIONS

### ⚠ WARNING

Indicates a potentially hazardous situation that, if not avoided, could result in death or serious personal injury.

### ⚠ CAUTION

Indicates a situation that, if not avoided, could result in damage to product or property.

**NOTE:** Identifies tips, helpful hints and maintenance information the owner/operator should know.

Please become familiar with and inform users about the warning and instruction labels on the back of the blade!

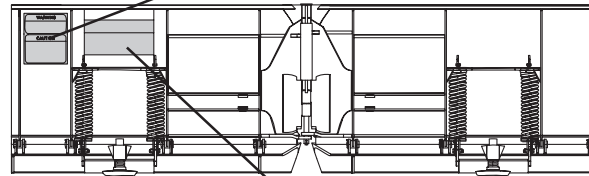

### Warning and Caution Label

#### ⚠ WARNING

LOWER BLADE WHEN VEHICLE IS PARKED.  
REMOVE BLADE ASSEMBLY BEFORE PLACING VEHICLE ON HOIST.  
DO NOT EXCEED GVWR OR GAWR INCLUDING BLADE AND BALLAST.

#### ⚠ CAUTION

READ OWNER'S MANUAL BEFORE OPERATING OR SERVICING SNOWPLOW.  
TRANSPORT SPEED SHOULD NOT EXCEED 45 MPH. REDUCE SPEED UNDER ADVERSE TRAVEL CONDITIONS.  
PLOWING SPEED SHOULD NOT EXCEED 10 MPH.  
SEE YOUR SALES OUTLET FOR APPLICATION RECOMMENDATIONS.

### Instruction Label

INSTRUCTIONS

### MOUNTING PLOW (ON)

Read Owner's Manual for complete instructions.

**STEP 1**

After seating plow horns in receiver brackets, pull Handle up; Shoe will lift off the ground.

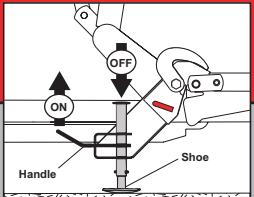

**STEP 2**

Pull and hold Lock Pin out; then rotate Handle UP and release Lock Pin. It must lock into UPPER hole. Stand Hook must grip Receiver Pin.

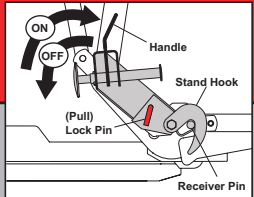

**STEP 3**

Plug in electrical connections. Repeat steps 1 and 2 on other side of plow.

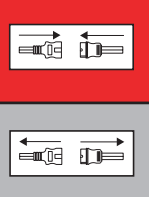

**STEP 3**

Push down top of Shoe; Shoe will be on the ground. Repeat steps 2 and 3 on other side of plow. Back vehicle away.



**STEP 2**

Pull and hold Lock Pin out; then rotate Handle DOWN and release Lock Pin. It must lock into LOWER hole.

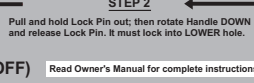

**STEP 1**

After lowering blade and turning control off, disconnect electrical connections.

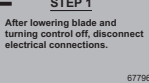

### REMOVING PLOW (OFF)

Read Owner's Manual for complete instructions.

67796

Patents: US 4,999,935; 5,420,480; RE 35,700; 6,145,222; 6,209,231; 6,283,470; 6,526,677; CAN 2,060,425; patents pending.

# SAFETY INFORMATION

## SAFETY PRECAUTIONS

Improper installation and operation could cause personal injury, and/or equipment and property damage. Read and understand labels and the *Owner's Manual* before installing, operating, or making adjustments.

### ⚠ WARNING

Lower blade when vehicle is parked. Temperature changes could change hydraulic pressure, causing the blade to drop unexpectedly or damaging hydraulic components. Failure to do this can result in serious personal injury.

### ⚠ WARNING

Remove blade assembly before placing vehicle on hoist.

### ⚠ WARNING

Keep 8' clear of the blade when it is being raised, lowered or angled. Do not stand between the vehicle and blade or directly in front of the blade. If the blade hits or drops on you, you could be seriously injured.

### ⚠ WARNING

Keep hands and feet clear of the blade and T-frame when mounting or removing the snowplow. Moving or falling assemblies could cause personal injury.

### ⚠ WARNING

Do not exceed GVWR or GAWR including blade and ballast. The rating label is found on the driver-side vehicle door cornerpost.

### ⚠ CAUTION

Refer to the current Selection List for minimum vehicle recommendations and ballast requirements.

### ⚠ CAUTION

To prevent accidental movement of the blade, always turn the ON/OFF switch to OFF whenever the snowplow is not in use. The control indicator light will turn off.

## PERSONAL SAFETY

- Wear only snug-fitting clothing while working on your vehicle or snowplow.
- Do not wear jewelry or a necktie, and secure long hair.
- Wear safety goggles to protect your eyes from battery acid, gasoline, dirt and dust.
- Avoid touching hot surfaces such as the engine, radiator, hoses and exhaust pipes.
- Always have a fire extinguisher rated BC handy, for flammable liquids and electrical fires.

## FIRE AND EXPLOSION

### ⚠ WARNING

Gasoline is highly flammable and gasoline vapor is explosive. Never smoke while working on vehicle. Keep all open flames away from gasoline tank and lines. Wipe up any spilled gasoline immediately.

Be careful when using gasoline. Do not use gasoline to clean parts. Store only in approved containers away from sources of heat or flame.

## VENTILATION

### ⚠ WARNING

Vehicle exhaust contains deadly carbon monoxide (CO) gas. Breathing this gas, even in low concentrations, could cause death. Never operate a vehicle in an enclosed area without venting exhaust to the outside.

## BATTERY SAFETY

### ⚠ CAUTION

Batteries normally produce explosive gases which can cause personal injury. Therefore, do not allow flames, sparks or lit tobacco to come near the battery. When charging or working near a battery, always cover your face and protect your eyes, and also provide ventilation.

Batteries contain sulfuric acid which burns skin, eyes and clothing.

Disconnect the battery before removing or replacing any electrical components.

# SAFETY INFORMATION

## HYDRAULIC SAFETY

### WARNING



Hydraulic fluid under pressure can cause skin injection injury. If you are injured by hydraulic fluid, get medical attention immediately.

- Always inspect hydraulic components and hoses before using. Replace any damaged or worn parts immediately.
- If you suspect a hose leak, DO NOT use your hand to locate it. Use a piece of cardboard or wood.

## TORQUE CHART

### CAUTION

Read instructions before assembling. Fasteners should be finger tight until instructed to tighten according to torque chart. Use standard methods and practices when attaching snowplow including proper personal protective safety equipment.

Recommended Fastener Torque Chart (Ft.-Lb.)			
Size	 SAE Grade 2	 SAE Grade 5	 SAE Grade 8
1/4-20	6	9	13
5/16-18	11	18	28
3/8-16	19	31	46
3/8-24	24	46	68
7/16-14	30	50	75
1/2-13	45	75	115
9/16-12	66	110	165
5/8-11	93	150	225
3/4-10	150	250	370
7/8-9	150	378	591
1-8	220	583	893
Metric Grade 8.8 (Ft.-Lb.)			
Size	Torque	Size	Torque
M 6	7	M 12	60
M 8	17	M 14	95
M 10	35	M 16	155
These torque values apply to fasteners except those noted in the instruction.			

# SYSTEM OVERVIEW – BLADE, T-FRAME & LIFT ASSEMBLIES

## SNOWPLOW COMPONENTS

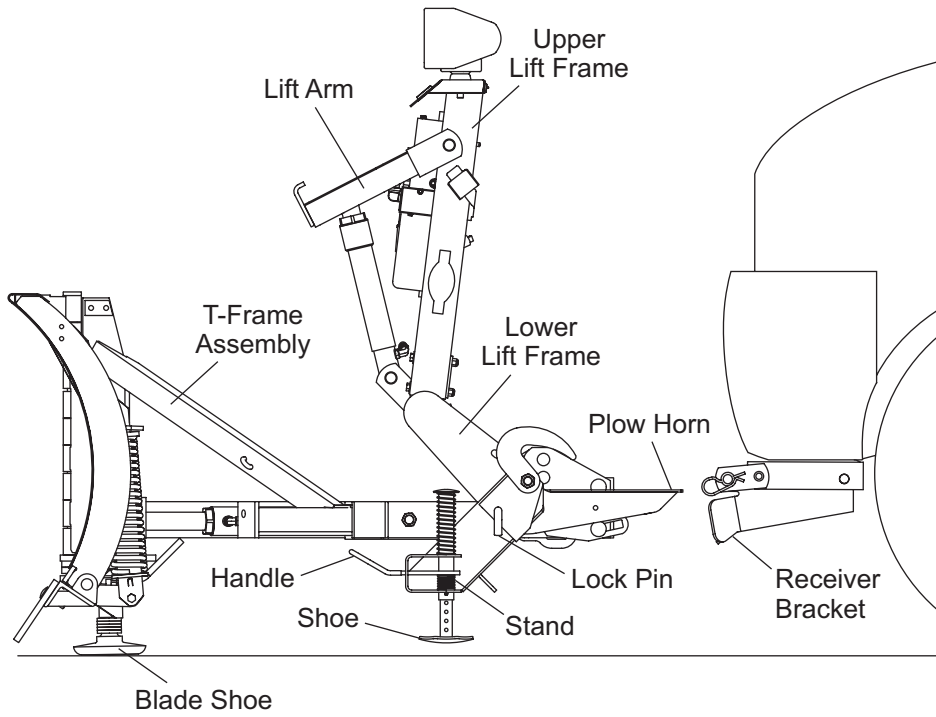

## SECURING PIVOT BAR TO T-FRAME

1. Install a 1" jam nut and tighten to 25 ft-lb, then loosen 1/16 turn.
2. Hold 1" cap screw and jam nut to prevent rotation, and install 1" locknut. Tighten locknut securely against jam nut.

**NOTE:** When properly adjusted, pivot bar should pivot freely without any looseness.

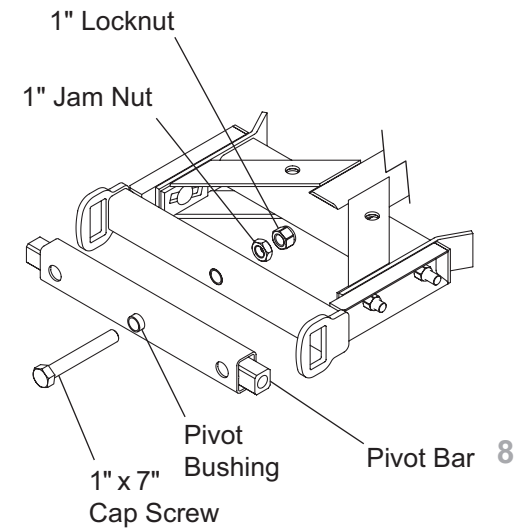



# SYSTEM OVERVIEW – BLADE, T-FRAME & LIFT ASSEMBLIES

## PIVOT PLATES

1. Measure the distance "d" from the ground to the top edge of the receiver bracket. Measure both sides and determine average value "d".

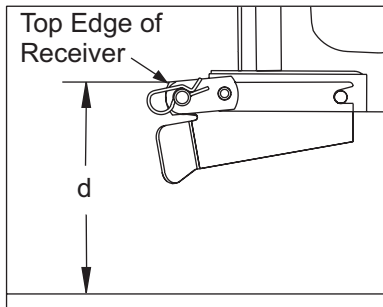

2. Use dimension "d" from Step 1, and the following chart to determine the proper pivot plate mounting position and pivot hole selection.

**Pivot Plate Configuration Chart**

Dimension "d"	Config.	Stacking Stop
13.0"–14.5"	1	No
14.5"–16.0"	2	Yes
16.0"–17.5"	3	Yes
17.5"–19.0"	4	Yes

**Pivot Plate Mounting and Hole Positions for Configurations 1 & 2**

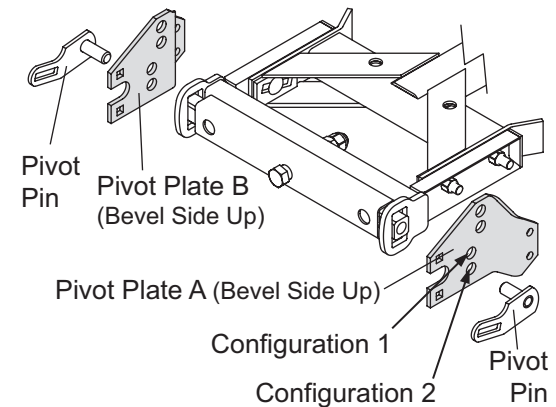

**Pivot Plate Mounting and Hole Positions for Configurations 3 & 4**

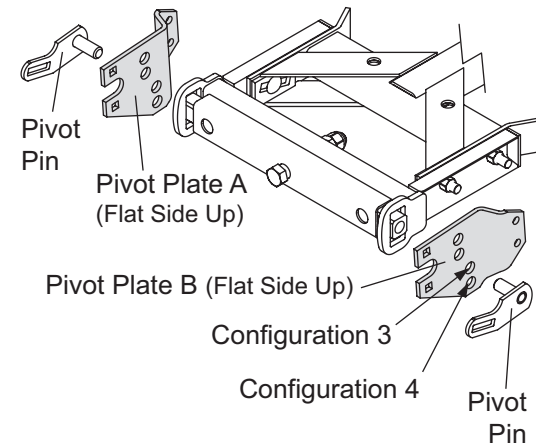

# SYSTEM OVERVIEW – BLADE, T-FRAME & LIFT ASSEMBLIES

## INITIAL STAND SHOE SETUP

The illustration below shows the recommended starting positions for configuring your stand shoes.

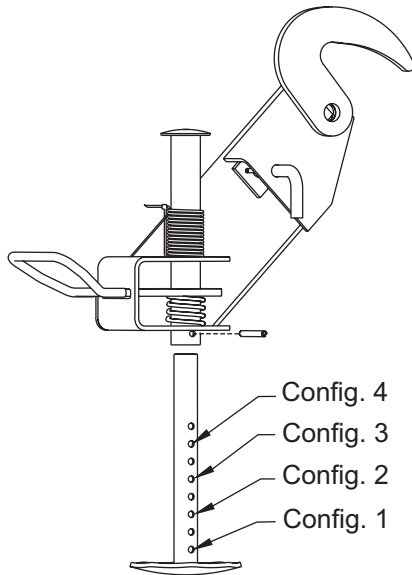

## STAND SHOE ADJUSTMENT

1. Attach plow to the vehicle mount. With plow lowered to the ground and on level pavement, measure the dimension from the ground to the center of the pivot bar cap screw. This dimension must be 9-3/4" to 11-1/4".
2. With the plow attached and on the ground, place the stand arm in the lower position with the lock pin engaged and with the stand shoe fully retracted in the "up" position. Measure the distance from the ground to the bottom of the stand shoe. This distance

should be 1-3/8" to 2-1/8". The stand can be adjusted to achieve this dimension by removing the roll pin and selecting the proper hole in the stand stem. When the stand height is correct, cut and remove the spring tie.

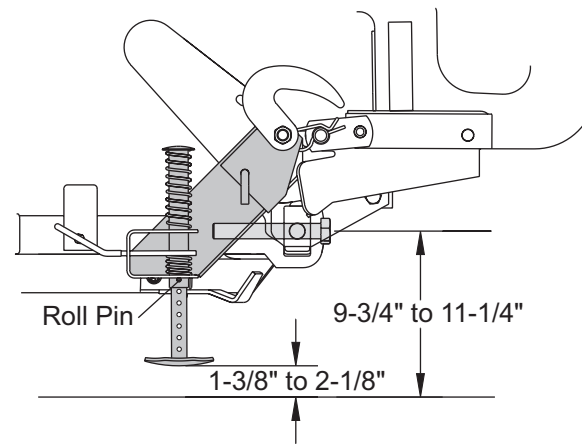

# SYSTEM OVERVIEW – BLADE, T-FRAME & LIFT ASSEMBLIES

## STACKING STOP CONFIGURATION

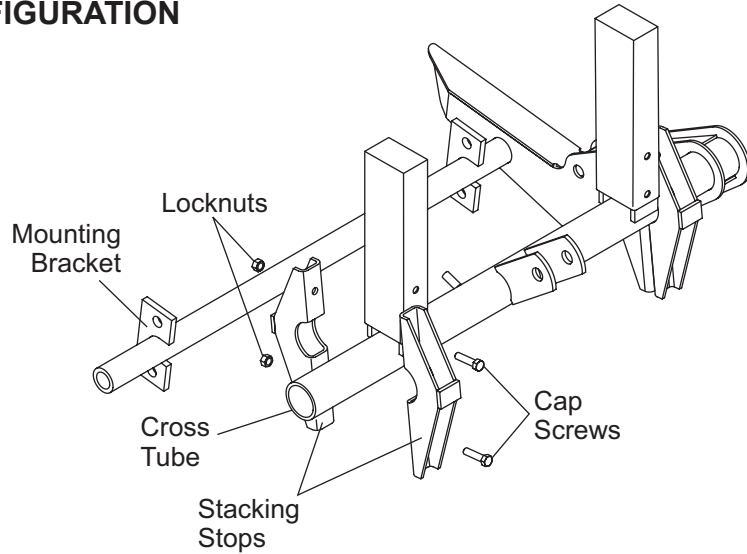

**NOTE:** Stacking stops are used only with configurations 2, 3 and 4. Stacking stops are not used for configuration 1.

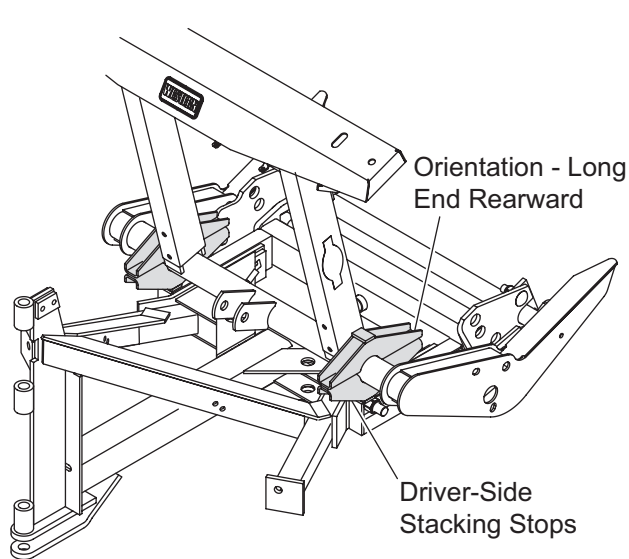

**Configuration 2**

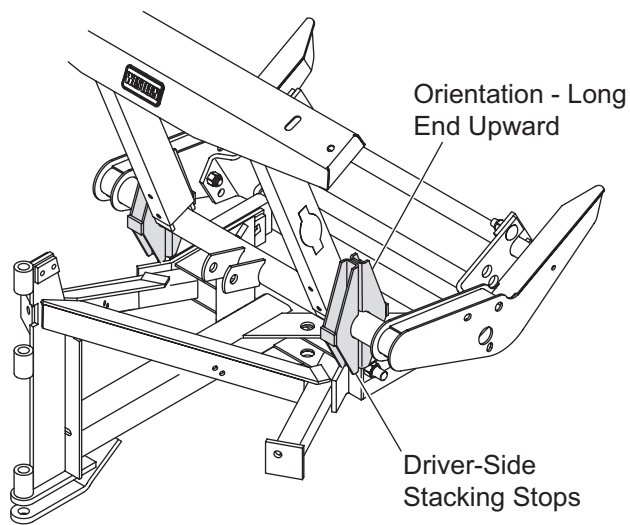

**Configuration 3**

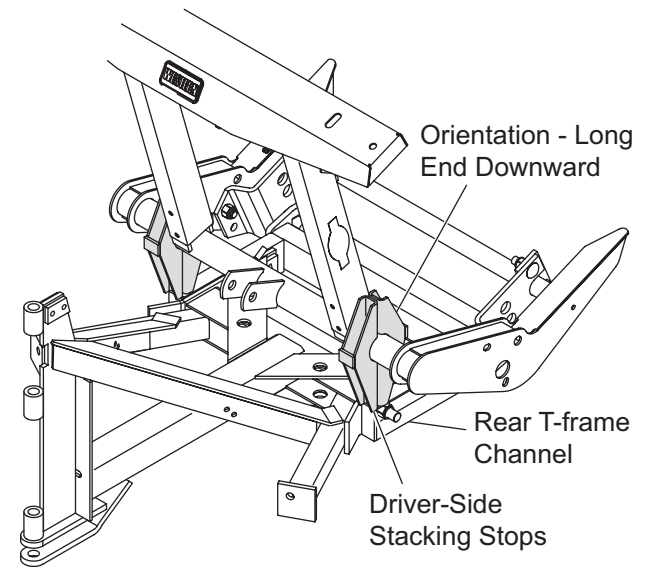

**Configuration 4**

## SYSTEM OVERVIEW – BLADE, T-FRAME & LIFT ASSEMBLIES

### T-FRAME LEVELING ADJUSTMENT

After the plow has been installed on the vehicle in the correct configuration, a fine adjustment can be made to bring the cutting edges of the plow in full contact with the ground across the entire cutting edge. This adjustment feature should be used as the cutting edges begin to wear in order to maintain an even wear pattern across both cutting edges and provide good scraping action.

1. Plow must be installed on a properly ballasted vehicle, in the correct configuration.
2. Vehicle and plow must be on a level surface.
3. Temporarily remove the blade shoes during this adjustment procedure.
4. Place blade wings in scoop position on the ground with no tension on lift chains.

5. Loosen the locking bolts and the pivot bolts on the T-frame just enough to allow the lock plates to move back and forth freely. (See figure below.)

It may be necessary to pry one or both locking plates loose in order to relieve any tension in the T-frame and allow the blade to find a level position.

6. Raise and lower the blade several times. The cutting edge should be contacting the level surface across the full length of the cutting edge.

7. Move the locking plates rearward by hand as far as they will go and tighten the locking bolts and the pivot bolts to 250 ft-lb.
8. Verify that the cutting edges remain in full contact with the ground while the wings are shifted from the scoop position to a Vee position.
9. Reinstall blade shoes.

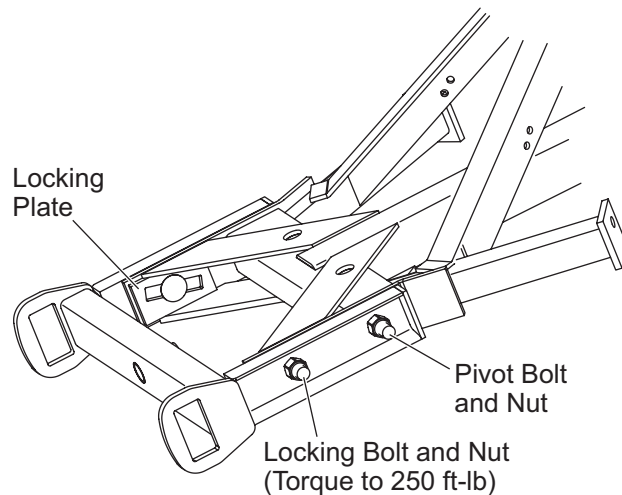

## SYSTEM OVERVIEW – BLADE, T-FRAME & LIFT ASSEMBLIES

### BLADE SPRING REPLACEMENT TOOL (PN 20043)

#### **CAUTION**

Servicing the trip springs without special tools and knowledge could result in personal injury.

1. Insert the threaded rod in through the hole in the channel weldment. Be sure the threaded hole in the tab on the rod is nearest to the channel.
2. Place the assembly on to the top anchor above the spring as illustrated. Be sure to place the spring bar in between the tabs on the rod. Insert the 1/2" x 1-1/2" Gr. 5 cap screw through the outside tab, through the hole in the spring bar, and tighten into the threaded hole.
3. Drop the 1/2" flat washer Gr. 8 over the threaded rod and fasten the nut to the threaded rod. Tighten the nut until the spring bar is raised enough to insert the pin through the pin hole. Center the pin within the hole.
4. Loosen the nut to lower the spring bar. Remove the spring tool assembly by removing the 1/2" cap screw.
5. Remove the spring from the blade by removing the bolt from the bottom of the spring bar.
6. Insert the new spring with the spring bar up through the top anchor on the blade. Fasten the bottom of the spring bar to the anchor on the trip edge with the previously removed fasteners. Tighten.
7. Repeat Steps 1 and 2 above.
8. Repeat Step 3 above, except remove the pin from the spring bar.
9. Repeat Step 4 above.

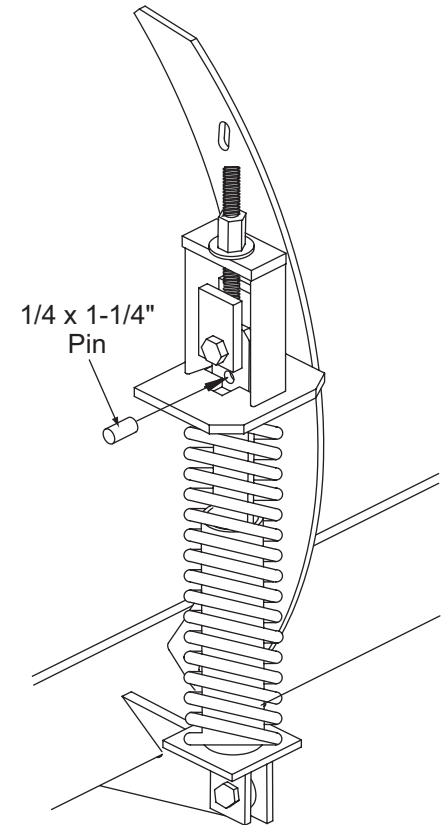
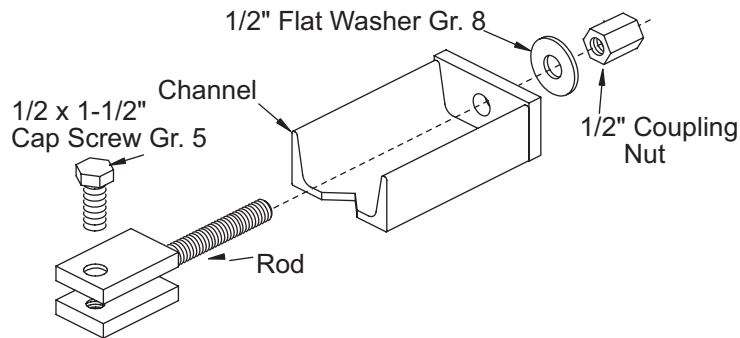

# SYSTEM OVERVIEW – BLADE, T-FRAME & LIFT ASSEMBLIES

## LIFT ARM & LIFT RAM INSTALLATION

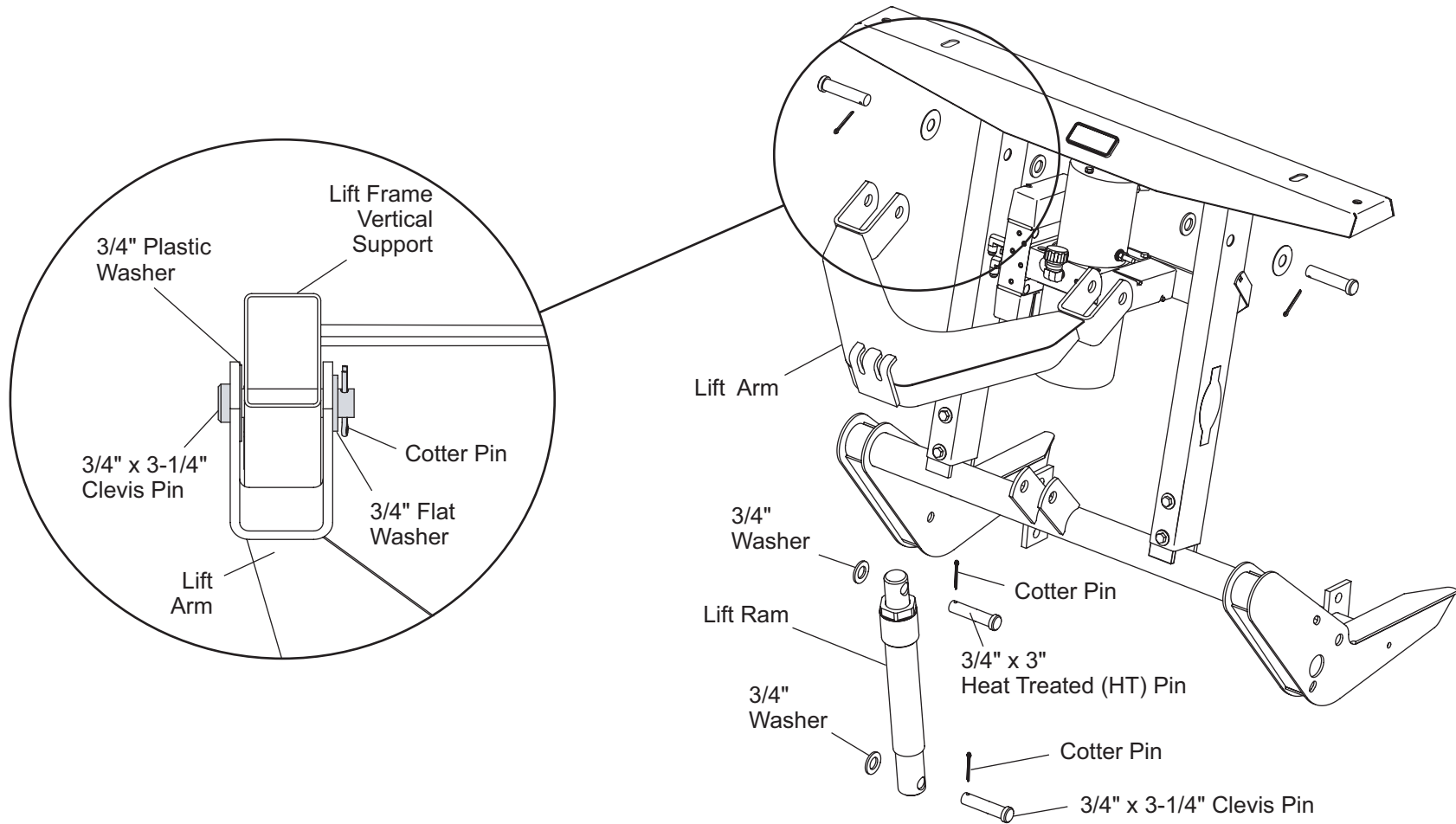

# SYSTEM OVERVIEW – BLADE, T-FRAME & LIFT ASSEMBLIES

## HEADLAMP BEAM AIMING

Torque headlamp fasteners to 45 ft-lb once correct visual aim is achieved.

1. Place vehicle on a level surface 25 feet in front of a matte-white screen, such as a garage door. The screen should be perpendicular both to the ground and to the vehicle centerline.
2. The vehicle should be equipped for normal operation. The snowplow blade should be in place and in raised position. Below are steps listed by the Society of Automotive Engineers (SAE) pertinent to headlamp aiming in specification #SAE J599d.
3. Prepare vehicle for headlamp aim or inspection. Before checking beam aim, the inspector will:
  - a. Remove ice or mud from under fenders.
  - b. Set tire inflation pressures to the values specified on vehicle information label.
  - c. Check springs for sag or broken leaves.
  - d. See that there is no load in the vehicle other than the driver and ballast as specified in the Selection List.

- e. Check functioning of any automatic vehicle leveling systems and specific manufacturer's instructions pertaining to vehicle preparation for headlamp aiming.
  - f. Clean lenses.
  - g. Check for bulb burnout and proper beam switching.
  - h. Stabilize suspension by rocking vehicle sideways.
4. Mark (or tape) the vertical centerline of the snowplow headlamps and the vertical centerline of the vehicle on the screen. Mark the horizontal centerline of the snowplow headlamps on the screen (distance from ground to snowplow headlamp centers).
  5. Align the top edge of the high intensity zone of the snowplow lower beam below the horizontal centerline and the left edge of the high intensity zone on the vertical centerline for each snowplow headlamp. (Refer to diagram below.)

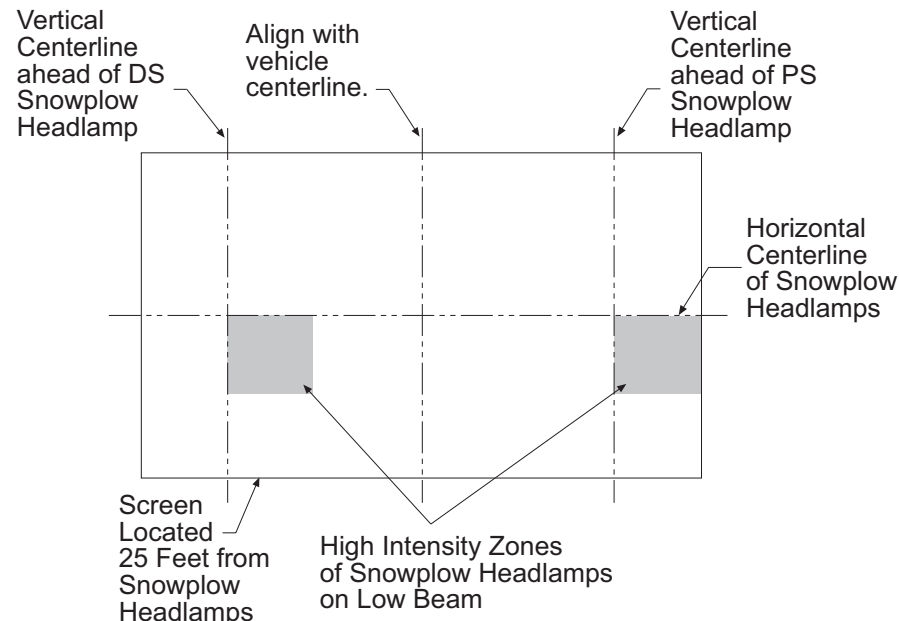

## VEHICLE LIGHTING CHECK

Check the operation of vehicle and plow lights with plow mounted to vehicle and all harnesses connected.

- **Turn Signals and Parking Lamps**
- **Headlamps**
- **Daytime Running Lamps (DRLs)**
- **Joystick Control or CabCommand Control**  
The control indicator light should light whenever the control ON/OFF switch and the ignition (key) switches are both in the ON Position. The snowplow electrical plugs must be connected to the vehicle electrical plugs.

# SYSTEM OVERVIEW – HYDRAULIC

## FloStat® HYDRAULIC SYSTEM

Western Products' FloStat hydraulic system provides a fast and uniform speed of lifting and angling. The system raises the blade in two seconds, and all angling functions are less than five seconds. For hydraulic fluid type and filling instructions, see Hydraulic System in the Maintenance section of the Owner's Manual.

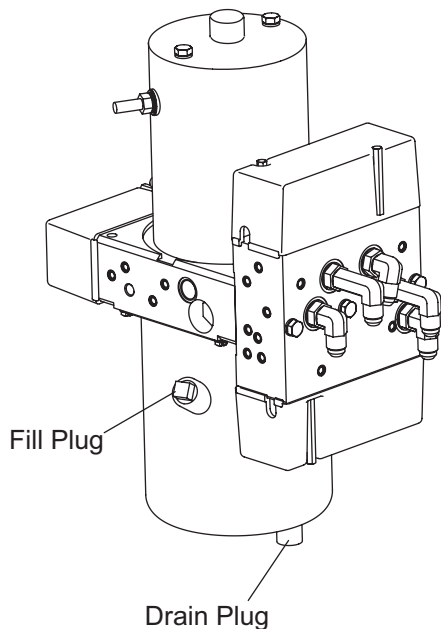

## SPECIFICATIONS

### Relief Valve Settings

- Pump relief valve = 1750 psi. 2-1/2–2-3/4 turns CCW from fully seated
- Primary relief valve = 3500 psi. 1-1/2–1-3/4 turns CCW from fully seated
- Secondary relief valve = 4000 psi. 1-1/4–1-1/2 turns CCW from fully seated

### Fluid Capacity (Hydraulic Fluid)

- Unit Reservoir = 1-3/4 Quarts
- System Total = 2-1/2 Quarts

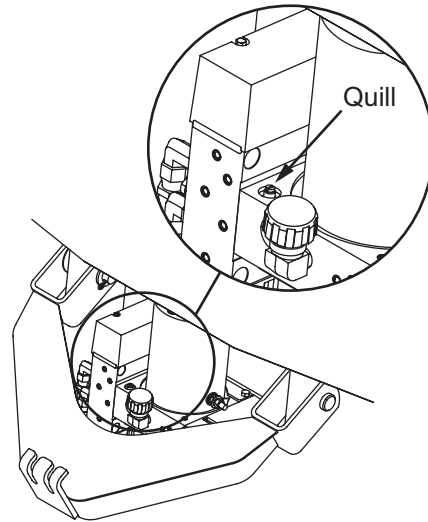

### Hydraulic Fluid

#### ⚠ CAUTION

**Do not mix different types of hydraulic fluid. Some fluids are not compatible and may cause performance problems and product damage.**

Use WESTERN® High Performance Fluid to -40°F (-40°C) or other fluid conforming to military specification MIL-H-5606A, such as Mobil Aero HFA or Shell AeroShell® Fluid 4. Use of other than these recommended fluids may cause poor hydraulic system performance and damage to internal components.

### Solenoid Valve Spool

- Approx. Solenoid Valve Spool Travel = 0.07" for 3- and 4-way valves. Spool travel for 2-way valves not detectable with voltage applied to coil.

### Pump Motor

12V DC with +/- connection
1700–1800 psi pump relief valve
3950–4050 psi angling relief valve
4.5" dia. 1.04 kw motor
Hydraulic Hose SAE 100R1

### Electrical System (Approximate)

- Solenoid Coil Resistance = 7 Ohms at room temperature
- Solenoid Coil amp. Draw = 1.5 amp
- Motor Relay Coil Resistance = 16–17 Ohm
- Motor Relay Amp. Draw = 0.7 amp
- Maximum Motor Amp. Draw = 190 amp at 1750 psi.
- Switch Accessory Lead Draw = 0.75 amp

### Vehicle Control Harness Fuses

- Park/Turn = 15 amp (Automotive Blade-Type Fuses)
- Control = 10 amp (Automotive Blade-Type Fuses)

### Fastener Torque

- Pump Bolts = 150–160 in-lb
- Motor Bolts = 30–40 in-lb
- Reservoir Bolts = 15–20 in-lb
- Cartridges = 120–144 in-lb
- Check Valves = 120–144 in-lb
- Coil Nuts = 48–60 in-lb
- Secondary Manifold Block Assembly Bolts = 105–115 in-lb
- **Angle Ram**  
Piston Locknuts = 100–120 ft-lb  
Gland Nuts = 150–180 ft-lb

AeroShell® is a registered (®) trademark of Shell Oil Company.



## SYSTEM OVERVIEW – HYDRAULIC

---

### HYDRAULIC FITTING AND HOSE INSTALLATION

---

**NOTE: Overtightening JIC hose fitting ends will result in a fractured fitting.**

---

Do not use any type of sealant or tape on the fittings or hoses. This could damage product. Always use two wrenches to ensure proper tightening of fittings and hoses.

**Use the following procedure to install SAE O-ring fittings in valve block and rams.**

1. Turn jam nut on fitting as far back as possible.
2. Lubricate O-ring with clean hydraulic fluid.
3. Screw fitting into port by hand until the washer contacts port face and shoulder of the jam nut threads.
4. Unscrew fitting to proper position no more than one full turn.
5. Using two wrenches, hold fitting body in position and tighten jam nut until the washer again contacts port face, then tighten an additional 1/8 to 1/4 turn to lock fitting in place. Final torque on the jam nut should be approximately 20 ft-lb.

**Use the following procedure to install hydraulic hoses.**

1. Screw flare nut onto fitting flare and hand tighten.
2. Align hose so there are no twists or sharp bends.
3. Using two wrenches, hold the hose in position and tighten flare nut 1/8 to 1/4 turn beyond hand tight. Final torque on the flare nut should be approximately 20 ft-lb.

# SYSTEM OVERVIEW – HYDRAULIC

## HOSE ROUTING & FITTING ORIENTATION

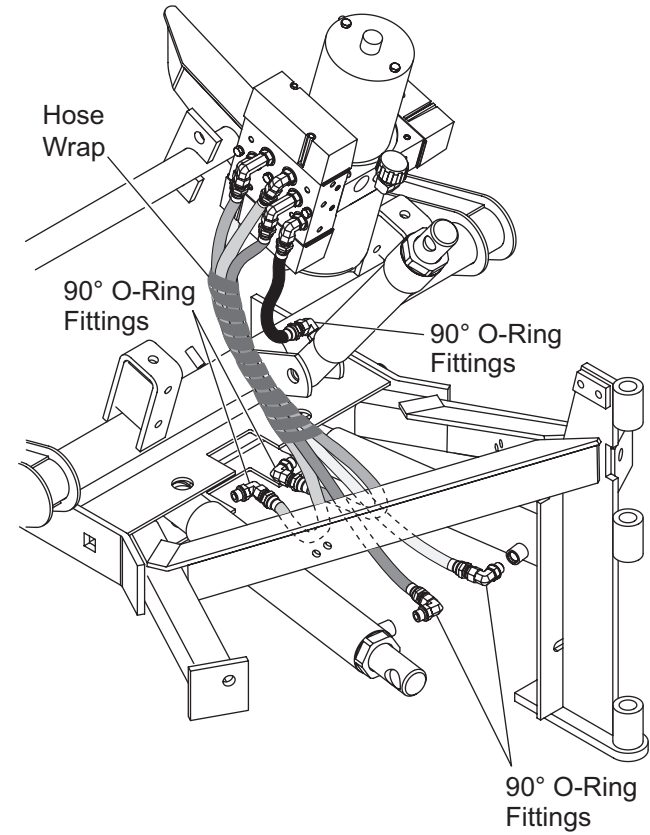
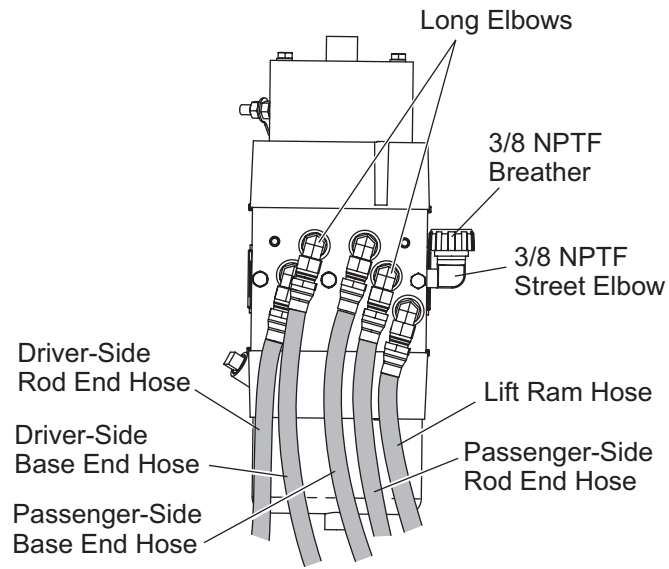

# SYSTEM OVERVIEW – HYDRAULIC

## ASSEMBLY

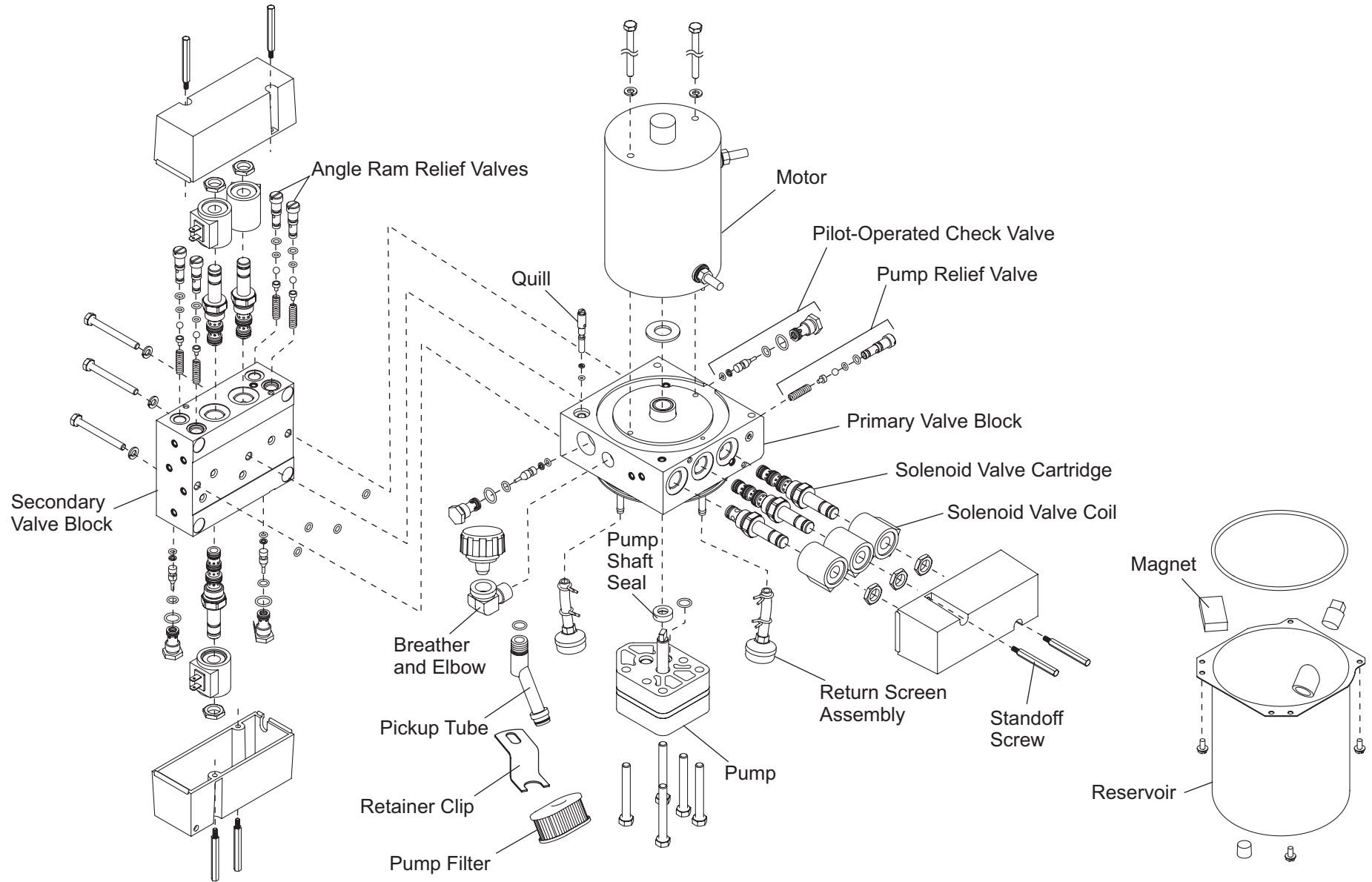

# SYSTEM OVERVIEW – HYDRAULIC

## CARTRIDGE VALVES

The MVP® snowplow FloStat® hydraulic system performs 10 blade movement functions.

All functions require the vehicle ignition (key) switch to be in the run or accessory position and the power to be activated on the snowplow cab control.

Nine of the ten hydraulic functions require energizing the electric motor, shifting of solenoid cartridge spools or activating P/O check valves. The tenth function, **lower**, does not energize the motor but requires shifting of solenoid cartridges.

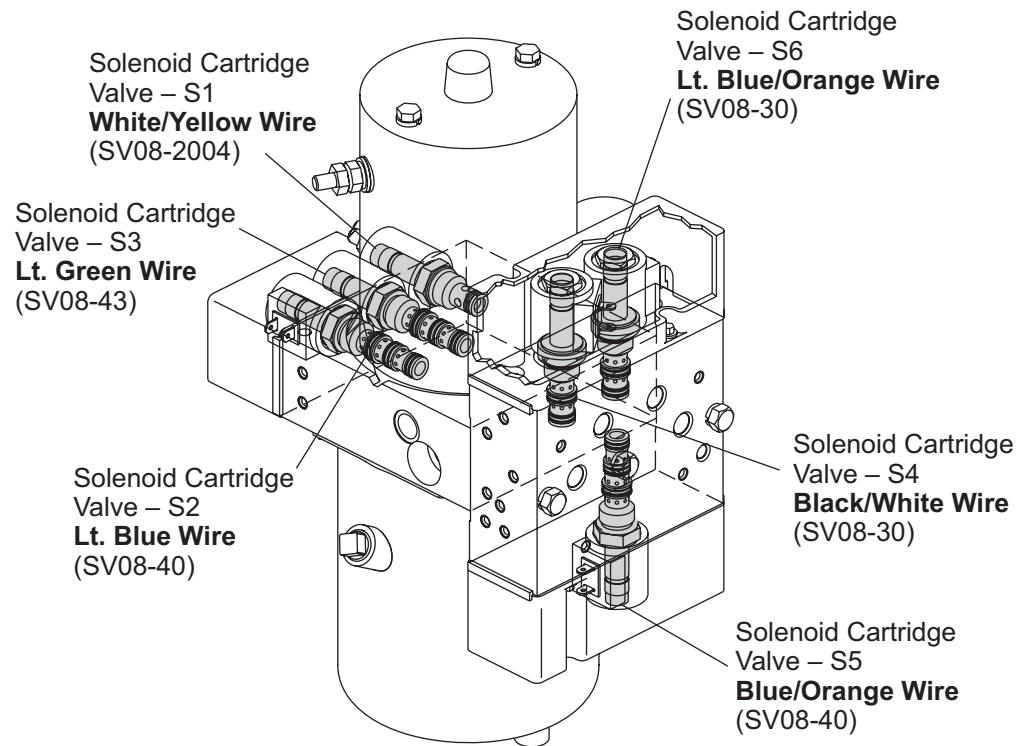

BLADE MOVEMENT		RAISE ↑	LOWER ↓	ANGLE RIGHT ↘	ANGLE LEFT ↙	VEE ∩	SCOOP ∪	RIGHT RETRACT ↖	RIGHT EXTEND ↗	LEFT RETRACT ↙	LEFT EXTEND ↘
MOTOR	M	ON		ON	ON	ON	ON	ON	ON	ON	ON
SV08-2004	S1		ON								
SV08-40	S2	ON			ON					ON	ON
SV08-43	S3	ON	ON			ON	ON				
SV08-30	S4						ON				ON
SV08-40	S5			ON	ON						
SV08-30	S6						ON		ON		

## SYSTEM OVERVIEW – HYDRAULIC

### RELIEF VALVES

Hydraulic fluid is trapped in the base end of the right ram by the right primary relief valve, right secondary relief valve, and P/O check valve (D). Hydraulic fluid is trapped in the base end of the left ram by the left primary relief valve, left secondary relief valve, and P/O check valve (C).

When the plow contacts an object on the front side of either wing, the force of the impact increases the hydraulic pressure in the base end of one ram. When the pressure

exceeds 3500 psi, the ram's primary relief valve opens allowing some of the hydraulic fluid to move from the base end of the rod end of the same ram.

Due to unequal displacement of the fluid between the base and rod ends of the ram, hydraulic pressure will continue to increase. When the pressure exceeds 4000 psi, the ram's secondary relief valve opens allowing the remaining hydraulic fluid back into the reservoir.

Relief Valve Settings	No. of Turns Backed Off (CCW) from Fully Seated	Approximate Relief Valve Pressure ( $\pm 50$ psi)
Pump Relief*	2-1/2 – 2-3/4	1750
Right or Left Angle Ram Primary Relief**	1-1/2 – 1-3/4	3500
Right or Left Angle Ram Secondary Relief**	1-1/4 – 1-1/2	4000

\* See Pump Pressure Test section for details.

\*\* Be certain the ram primary relief valve stem is backed out 1/4 turn farther than the secondary relief valve stem.

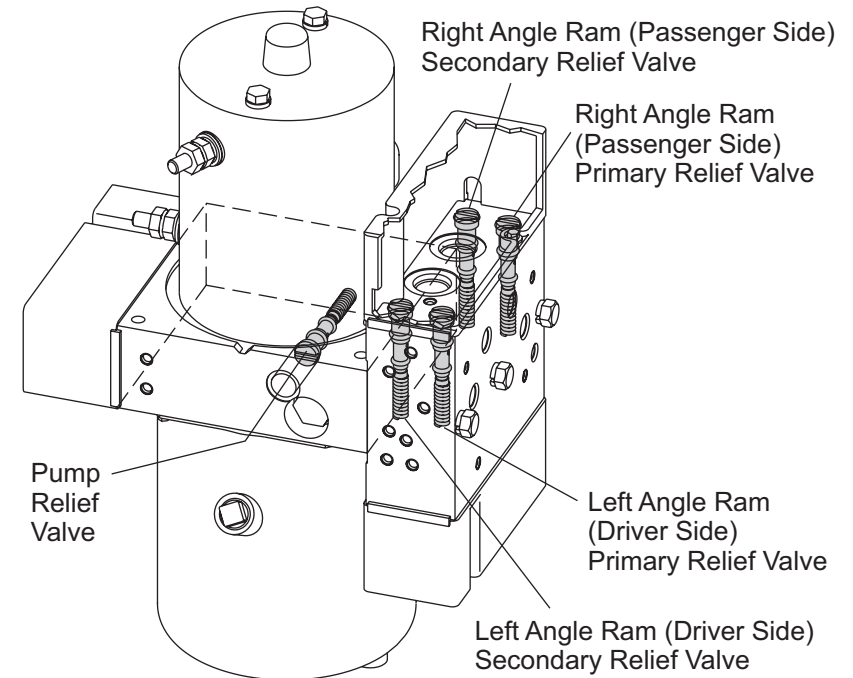

## SYSTEM OVERVIEW – HYDRAULIC

### PILOT-OPERATED CHECK VALVES

A pilot-operated check valve is designed to permit free flow in one direction and prevent flow in the reverse direction. The free reverse flow is permitted when a pilot pressure signal is applied to the pilot port and the valve is opened. These valves have very low internal leakage and are typically used to lock a ram in place until a function is changed.

**NOTE: Be sure replacement P/O check valve assemblies have the letter "V" stamped on the hex.**

P/O Check Functions	
A	Traps fluid for left ram rod end
B	Traps fluid for right ram rod end
C	Traps fluid for left ram base end
D	Traps fluid for right ram base end

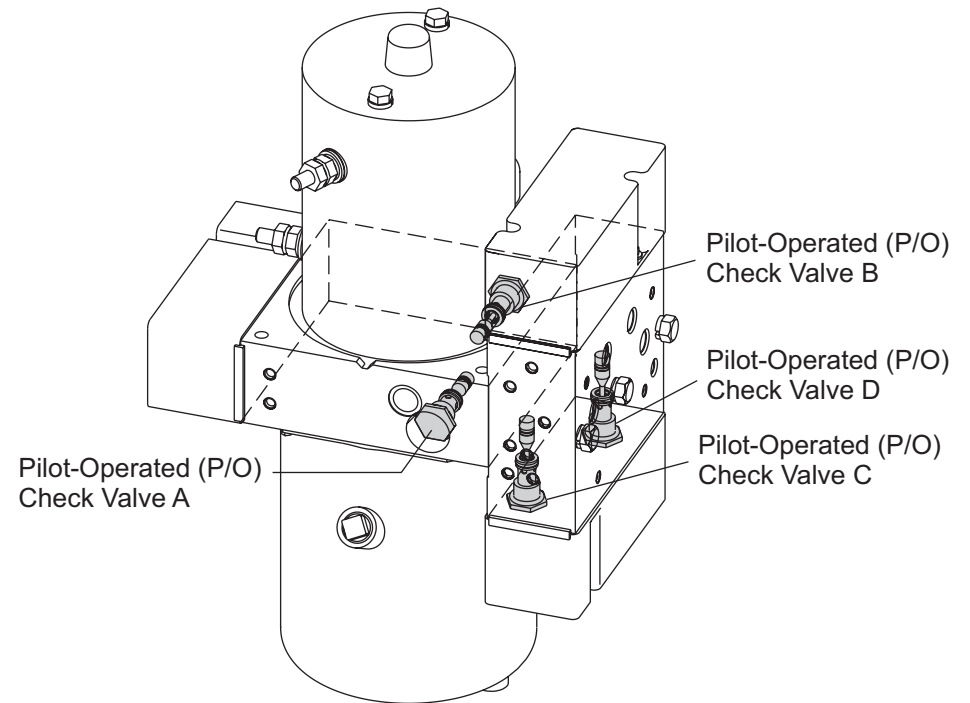

## SYSTEM OVERVIEW – HYDRAULIC

---

### SEAL AND O-RING INSTALLATION

1. Lubricate the seals and O-rings with hydraulic fluid.
2. Install the seals and O-rings in the **exact** orientation as shown.
3. **For single-acting (lift) rams:** Slide the gland nut over the split bearing end of the rod to prevent damaging the seals.
4. **For double-acting (angle) rams only:** Install the piston in the orientation shown. Tighten piston locknut to 100–120 ft-lb.
5. Carefully reassemble the ram.
6. Insert a 0.012" feeler gauge between the front surface of the cylinder tube face and the hex of the gland nut. Tighten the gland nut until it is snug against the feeler gauge.
7. Remove the feeler gauge, and tighten the gland nut an additional **1/4 turn**. This adjustment procedure will provide a torque of 150–180 ft-lb.

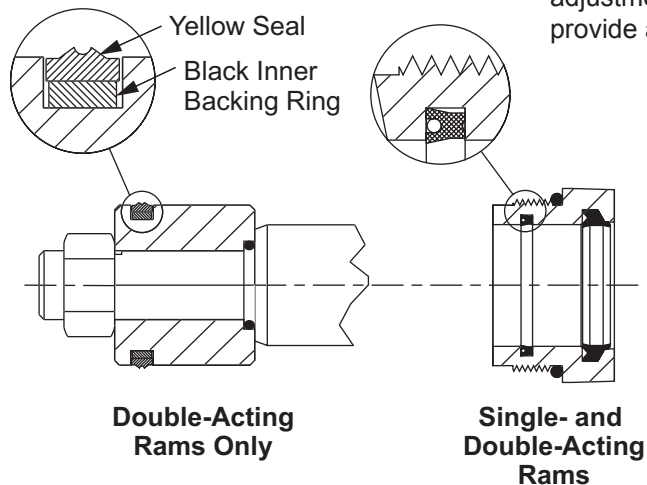

# SYSTEM OVERVIEW – ELECTRICAL

## WIRING

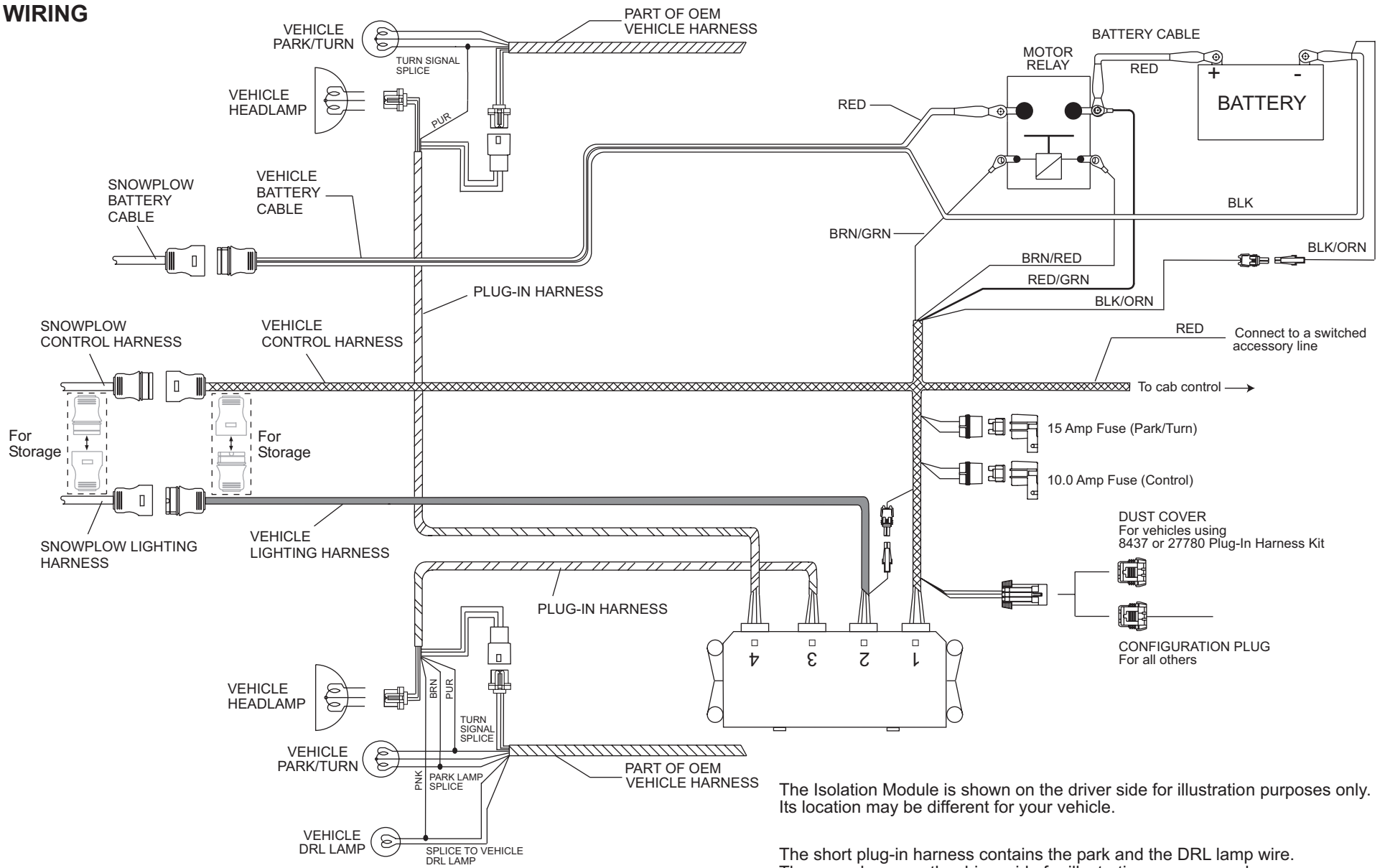

The Isolation Module is shown on the driver side for illustration purposes only. Its location may be different for your vehicle.

The short plug-in harness contains the park and the DRL lamp wire. They are shown on the driver side for illustration purposes only.



# SYSTEM OVERVIEW – CONTROLS

## GENERAL INFORMATION

### ⚠ WARNING

To prevent accidental movement of the blade, always turn the ON/OFF switch to OFF whenever the snowplow is not in use. The control indicator light will turn off.

The MVP® snowplow is equipped with one of three special controls – the CabCommand 9-button hand-held control, CabCommand 6-button hand-held control (early style) or a joystick-style control. The controls allow you to go from a V-plow, to a scoop, to a standard straight-blade plow, all at the touch of a button or single-lever movement.

Each control has its own ON/OFF switch with an indicator light to show when the control is powered up. Your vehicle ignition (key) switch controls a fused circuit that powers your cab control directly from the battery.

The ON/OFF switch on the cab control allows you to turn off the control and prevent blade movement even when the ignition switch is on. **The control ON/OFF switch serves as an emergency stop if required.**

All controls have internal fuses. See Fuse Replacement at the end of this section.

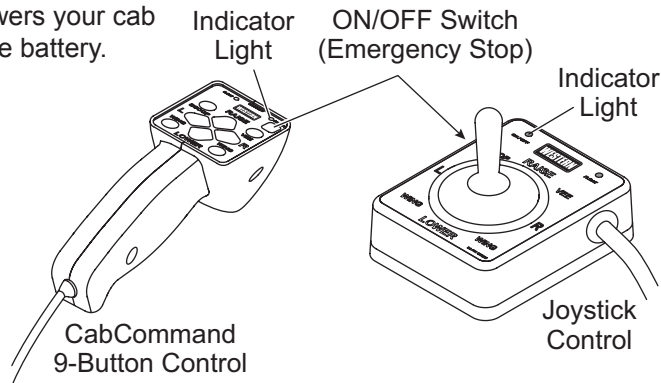
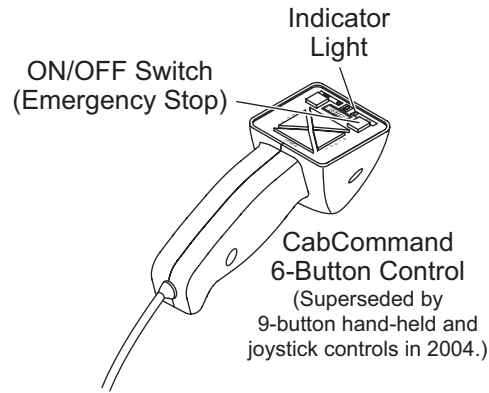

## ADAPTER CABLE (PN 66760K)

The MVP adapter cable allows you to use a straight blade UltraMount® snowplow with a straight blade

control (either a CabCommand or solenoid control) without changing the vehicle wiring system.

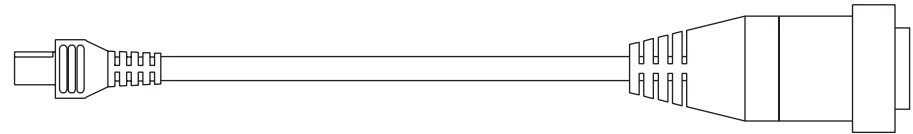

## SYSTEM OVERVIEW – CONTROLS

### CabCommand HAND-HELD CONTROL (9 BUTTON)

#### **⚠ WARNING**

To prevent accidental movement of the blade, always turn the ON/OFF switch to OFF whenever the snowplow is not in use. The control indicator light will turn off.

1. Turn the vehicle ignition switch to the ON or the ACCESSORY position.
2. Press the ON/OFF switch on the control. The control indicator light glows red, indicating the control is on. The indicator light glows red whenever the control and the vehicle ignition switch are both on and the electrical connections to the plow are completed.

The ON/OFF switch operates as an emergency stop if required.

#### Function Time Outs

All control functions, except LOWER/Float, time out (stop) automatically after a period of time. This is to limit the amount of electrical energy required from the vehicle. The time-out period for the RAISE function is 3.0 seconds, while all others are 5.5 seconds.

**NOTE: If control function times out before desired blade movement is complete, refer to the General Diagnostic Table in the Troubleshooting section of this guide.**

#### Automatic Shutdown

The control will automatically turn off after being idle for 20 minutes.

#### Smooth Stop

The control automatically allows the blade to coast to a stop when the button is released. This results in smoother operation, reduces the shock to the hydraulic system and increases hose and valve life.

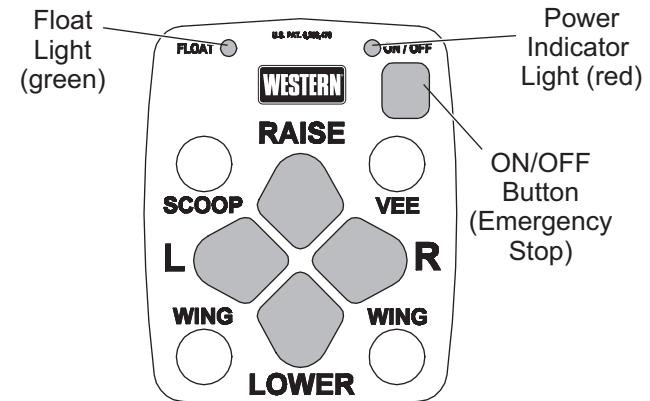

# SYSTEM OVERVIEW – CONTROLS

## Control Functions

### Raise, Lower, Float, Angle

The four diamond-shaped buttons in the center of the control face, when pressed, will result in the following blade movements:

**NOTE: If control function times out before desired blade movement is complete, refer to the General Diagnostic Table in the Troubleshooting section of this guide.**

Function	Description of Operation
<b>RAISE</b>	Press this button to raise the snowplow and cancel the float mode. Function times out after 3.0 seconds.
<b>LOWER</b>	Press this button to lower the snowplow. Release the button to stop blade at desired height.
<b>FLOAT</b>	Press the <b>LOWER</b> button and hold 3/4 second to activate this mode. The <b>FLOAT</b> indicator light in the upper left corner of the control face will illuminate. The blade will lower to the ground surface and follow the contour of the surface as it dips or raises. Function does not time out, but control will shut down after 20 minutes of nonuse. Press <b>RAISE</b> button momentarily to cancel float. Angling left or right will interrupt (stop) the float function while the blade angles, but will return to float when angling is complete.
<b>L – Angle Left</b>	With wings in a straight line, press the <b>L</b> button to move both wings to the angle left position to cast snow to the driver's left side. The left wing retracts while the right wing extends. Function times out after 5.5 seconds.
<b>R – Angle Right</b>	With wings in a straight line, press the <b>R</b> button to move both wings to the angle right position to cast snow to the driver's right side. The right wing retracts while the left wing extends. Function times out after 5.5 seconds.

### Scoop/Vee Blade Position

The two round buttons located to the left and right of the RAISE button move both wings at the same time into the following blade positions:

**NOTE: Blade wings may not move at the same speed.**

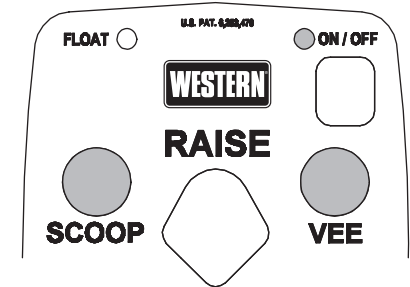

Function	Description of Operation
<b>SCOOP</b>	Press this button to extend both wings forward into the scoop position. Function times out after 5.5 seconds.
<b>VEE</b>	Press this button to retract both wings into the vee position. Function times out after 5.5 seconds.

### Wing Positions

The two round buttons located to the left and right of the LOWER button move either wing independently of the other as described below.

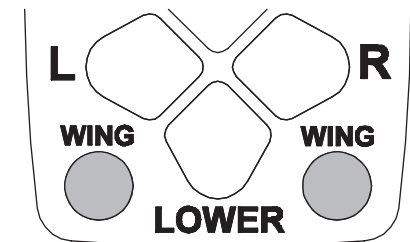

Function	Description of Operation
<b>L WING</b>	Press the round WING button on the left side of the control to move the left wing. The first time the button is pressed after the control is turned on or another function is used, the wing will extend. Repeated use of the same button, without using another function, results in movement in the opposite direction from the previous movement. Function times out after 5.5 seconds.
<b>R WING</b>	Press the round WING button on the right side of the control to move the right wing. The first time the button is pressed after the control is turned on or another function is used, the wing will extend. Repeated use of the same button, without using another function, results in movement in the opposite direction from the previous movement. Function times out after 5.5 seconds.

# SYSTEM OVERVIEW – CONTROLS

## JOYSTICK CONTROL

### ⚠ WARNING

To prevent accidental movement of the blade, always turn the ON/OFF switch to OFF whenever the snowplow is not in use. The control indicator light will turn off.

1. Turn the vehicle ignition switch to the ON or the ACCESSORY position.
2. Move the slide switch on the side of the control to the ON position. The control ON/OFF indicator light glows red, indicating the control is on. The indicator light glows red whenever the control and the vehicle ignition switch are both on and the electrical connections to the plow are completed.

The ON/OFF switch operates as an emergency stop if required.

### Function Time Outs

All control functions, except LOWER/Float, time out (stop) automatically after a period of time. This is to limit the amount of electrical energy required from the vehicle. The time-out period for the RAISE function is 3.0 seconds, while all others are 5.5 seconds.

**NOTE: If control function times out before desired blade movement is complete, refer to the General Diagnostic Table in the Troubleshooting section of this guide.**

### Automatic Shutdown

The control will automatically turn off after being idle for 20 minutes. To reactivate the control after a shut down, move ON/OFF switch to OFF, then back to ON.

### Smooth Stop

The control automatically allows the blade to coast to a stop when the lever returns to center position. This results in smoother operation, reduces the shock to the hydraulic system and increases hose and valve life.

### Control Lever Movement

From the center position, the control lever can be moved in one of eight (8) directions to control various movements of the snowplow blade. To change from one movement of the blade to another, the control lever must be moved back to the center position before selecting the desired function. Whenever the lever is released, it should spring back to the center position to stop blade movement.

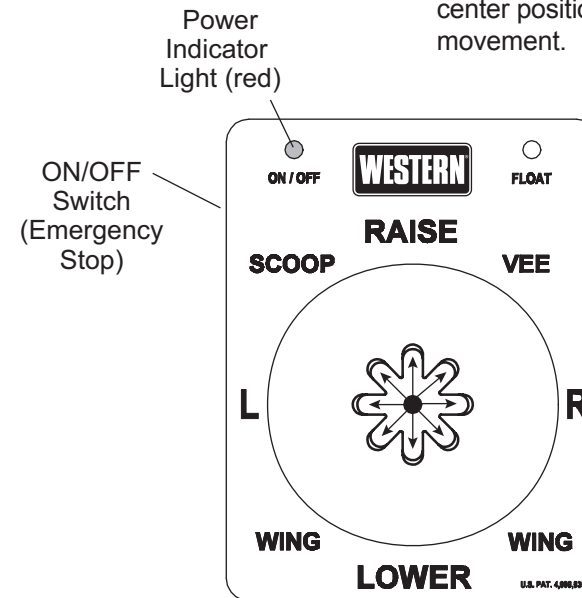

# SYSTEM OVERVIEW – CONTROLS

## Control Functions

### Raise, Lower, Float, Angle

Movement of the control lever in straight lines up and down or from side to side on the control body will result in the following blade movements:

**NOTE: If control function times out before desired blade movement is complete, refer to the General Diagnostic Table in the Troubleshooting section of this guide.**

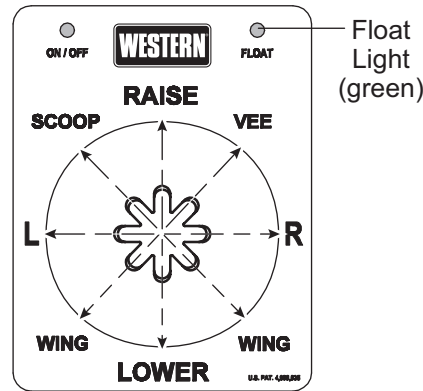

### Scoop/Vee Blade Position

Move the control lever from the center position toward the "SCO" of SCOOP or the "EE" of VEE on the face of the control body. The use of either of these slots will cause both the left and right wings to move at

the same time into the following blade positions:

**NOTE: Blade wings may not move at the same speed.**

Function	Description of Operation
<b>RAISE</b>	Move the control lever toward the top of the control body to raise the snowplow and cancel the float mode. Function times out after 3.0 seconds.
<b>LOWER</b>	Move the control lever toward the bottom of the control body to lower the snowplow. Release the lever to stop blade at desired height.
<b>FLOAT</b>	Move the control lever to the <b>LOWER</b> position and hold 3/4 second to activate this mode. The <b>FLOAT</b> indicator light in the upper right corner of the control face will illuminate. The blade will lower to the ground surface and follow the contour of the surface as it dips or raises. Function does not time out; however, control will shut down after 20 minutes of nonuse. Move lever to the <b>RAISE</b> position momentarily to cancel float. Angling left or right will interrupt (stop) the float function while the blade angles, but will return to float when angling is complete.
<b>L – Angle Left</b>	With wings in a straight line, move the control lever straight to the left to move both wings to the angle left position to cast snow to the driver's left side. The left wing retracts while the right wing extends. Function times out after 5.5 seconds.
<b>R – Angle Right</b>	With wings in a straight line, move the control lever straight to the right to move both wings to the angle right position to cast snow to the driver's right side. The right wing retracts while the left wing extends. Function times out after 5.5 seconds.

Function	Description of Operation
<b>SCOOP</b>	Move the control lever toward the word, SCOOP, on the control face to extend both wings forward into the scoop position. Function times out after 5.5 seconds.
<b>VEE</b>	Move the control lever toward the word, VEE, on the control face to retract both wings into the vee position. Function times out after 5.5 seconds.

### Wing Positions

Move the control lever from the center position toward the word, WING, on either side of the face of the control body. The use of either of

these slots will allow movement of either wing independently of the other as described below.

Function	Description of Operation
<b>L WING</b>	When the control lever is moved to the left side of <b>LOWER</b> , the left wing will move either in or out. The first time the lever is moved into the slot after the control is turned on or another function is used, the wing will extend. Repeated use of lever in the same slot, without using another function, results in movement in the opposite direction from the previous movement. Function times out after 5.5 seconds.
<b>R WING</b>	When the control lever is moved to the right side of <b>LOWER</b> , the right wing will move either in or out. The first time the lever is moved into the slot after the control is turned on or another function is used, the wing will extend. Repeated use of lever in the same slot, without using another function, results in movement in the opposite direction from the previous movement. Function times out after 5.5 seconds.

# SYSTEM OVERVIEW – CONTROLS

## CabCommand HAND-HELD CONTROL (6 BUTTON)

**NOTE:** In 2004, this control was superseded by the 9-button hand-held and joystick controls.

**⚠ WARNING**

To prevent accidental movement of the blade, always turn the ON/OFF switch to OFF whenever the snowplow is not in use. The control indicator light will turn off.

1. Turn the vehicle ignition switch to the ON position.
2. Press the ON/OFF button on the control. The power indicator light glows red indicating the control is on. The power indicator light glows red whenever the control and the vehicle ignition switch are both ON and the electrical connections to the plow are completed. **The ON/OFF button operates as an emergency stop if required.**

### Function Time Outs

Except for the LOWER function, all functions automatically time out, or stop, after a period of time. This helps prevent excessive battery drain.

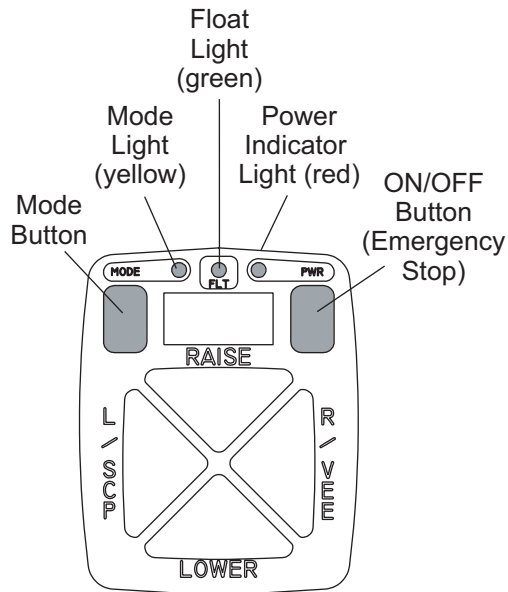

The RAISE function time-out period is 2.5 seconds, while all others are 4.25 seconds.

### Automatic Shutdown

If the snowplow control is not used for 20 or more minutes, it will automatically turn off.

### Smooth Stop

The control automatically allows the blade to coast to a stop. This results in a smoother operational "feel" and reduces shock to the hydraulic system, resulting in longer hose and valve life.

## Control Functions

### Straight Blade Mode (Default)

When the control is turned on, it automatically defaults to the straight blade mode. When the control is in the straight blade mode, the yellow MODE LIGHT near the MODE button in the upper left corner of the keypad is not illuminated or flashing.

The following functions are performed in the straight blade mode:

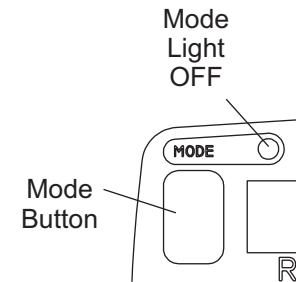

Button	Description of Operation
<b>RAISE</b>	Press this button to raise the snowplow and to cancel the float mode. <b>NOTE:</b> Snowplow will automatically stop raising after 2.5 seconds. To resume raising the snowplow, release the button and press again.
<b>LOWER</b>	Press this button to lower the snowplow. <b>NOTE:</b> After reaching the desired height, release the button. Holding the button down for more than 3/4 second will activate the float mode (indicated by green FLT LIGHT), which allows the blade to move up and down to follow the contour of the surface being plowed.
<b>L/SCP</b>	Press this button to angle both wings to the left.
<b>R/VEE</b>	Press this button to angle both wings to the right.

## SYSTEM OVERVIEW – CONTROLS

### Vee/Scoop Mode

To put the control into the vee/scoop mode, quickly press and release the MODE button. The yellow MODE LIGHT near the upper left corner of the keypad will light. Quickly pressing and releasing the MODE button will toggle the control between straight blade mode and vee/scoop mode.

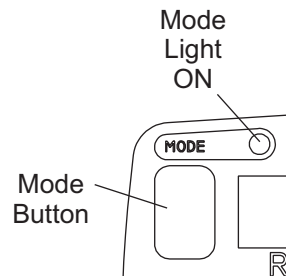

The following functions are performed in the vee/scoop mode:

**NOTE: Blade wings may not move at the same speed.**

Button	Description of Operation
<b>RAISE</b>	Press this button to raise the snowplow and to cancel the float mode. <b>NOTE:</b> Snowplow will automatically stop raising after 2.5 seconds. To resume raising the snowplow, release the button and press again.
<b>LOWER</b>	Press this button to lower the snowplow. <b>NOTE:</b> After reaching the desired height, release the button. Holding the button down for more than 3/4 second will activate the float mode (indicated by green FLT LIGHT), which allows the blade to move up and down to follow the contour of the surface being plowed.
<b>L/SCP</b>	Press this button to extend both wings to the scoop position.
<b>R/VEE</b>	Press this button to retract both wings to the vee position.

### Wing Mode

To put the control into the wing mode, press and hold the MODE button for about two seconds until the yellow MODE LIGHT near the upper left corner of the keypad is flashing. The L/SCP and R/VEE buttons are used to activate the four functions of the wing mode. The RAISE and LOWER buttons retain the same functions as the other modes.

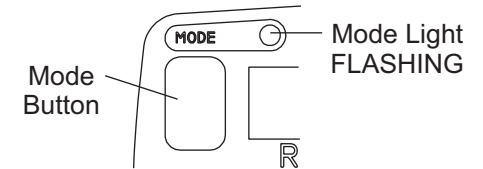

To deactivate the wing mode, quickly press and release the MODE button. This will put the control in the straight blade mode.

The following functions are performed in the wing mode:

Button	Description of Operation
<b>RAISE</b>	Press this button to raise the snowplow and to cancel the float mode. <b>NOTE:</b> Snowplow will automatically stop raising after 2.5 seconds. To resume raising the snowplow, release the button and press again.
<b>LOWER</b>	Press this button to lower the snowplow. <b>NOTE:</b> After reaching the desired height, release the button. Holding the button down for more than 3/4 second will activate the float mode (indicated by green FLT LIGHT), which allows the blade to move up and down to follow the contour of the surface being plowed.
<b>L/SCP</b>	Pressing this button the first time will retract the left wing. Pressing this button the next time will extend the left wing.
<b>R/VEE</b>	Pressing this button the first time will retract the right wing. Pressing this button the next time will extend the right wing.

# SYSTEM OVERVIEW – CONTROLS

## FUSE REPLACEMENT

The vehicle control harness contains two automotive blade-style fuses. The 15-amp fuse is for the snowplow park/turn power, and the 10-amp is for the snowplow control power. The 10-amp fuse is "hot" when the vehicle ignition switch is on and the electrical connections to the plow are completed.

If a problem should occur and fuse replacement is necessary, the replacement fuse should be of the same value as the original. Installing a fuse of a larger value could damage the system.

**CAUTION**  
Circuit board may be damaged by static electricity. Always touch ground before handling PC board.

The cab control contains two 5AFB printed circuit board (PCB) mounted fuses. These fuses are to protect the solid state devices that control the six solenoid valves and the motor relay coil. If the control does not function and the 10-amp fuse under the vehicle hood is not blown, one or both of these 5AFB PCB-mounted fuses may be blown.

If fuse F1 on the board is blown, the motor relay and solenoid coils S1, S2, and S3 will not function.

If fuse F2 on the board is blown, the solenoid coils S4, S5, and S6 will not function.

**NOTE: A 5-pack of replacement fuses is available (PN 69190).**

CabCommand  
9-Button Control

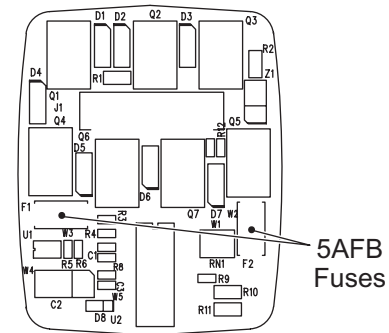

CabCommand  
6-Button Control  
(Superseded by  
9-button hand-held and  
joystick controls in 2004.)

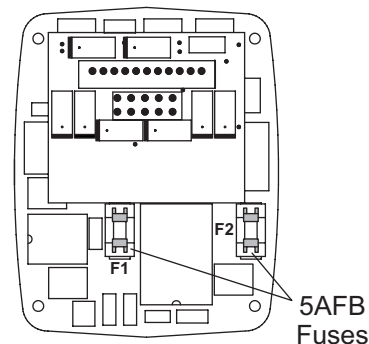

Joystick Control

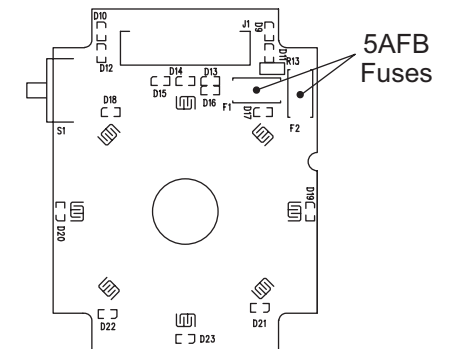



# SYSTEM OVERVIEW – CONTROLS

## TERMINAL REMOVAL TOOL

1. Gently insert the open end of the tool into the desired socket cavity in the 14-pin connector housing as illustrated.
2. Push it in until it bottoms out in the housing.
3. Gently pull the wire that corresponds with the socket cavity out of the housing.
4. Continue until the desired number of wires have been removed from the housing.
5. To reinsert the terminal gently push the terminal into its proper cavity until it locks into place.

**NOTE: A package of 10 solder-type terminal replacement pins is available (PN 22123).**

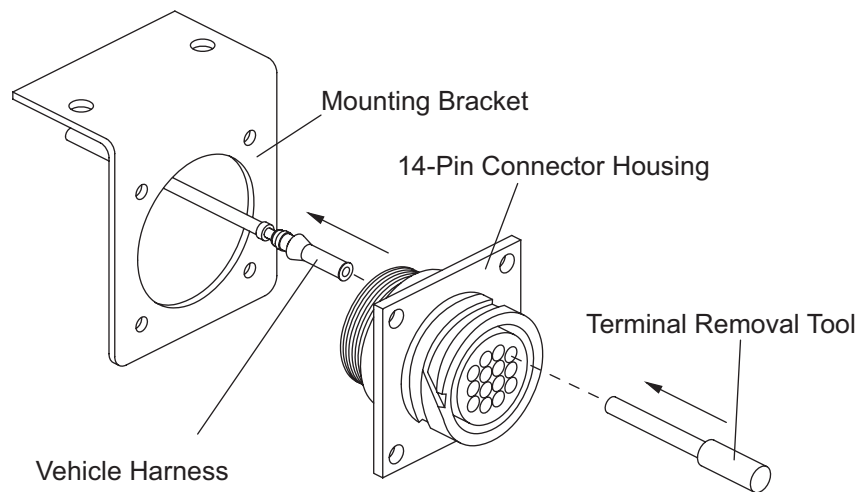

## REPLACING TERMINALS

1. Remove the damaged terminal from the end of the wire.
2. Strip 3/16" of insulation off the end of the wire as illustrated.
3. Push the solder-type terminal over the bared wire.

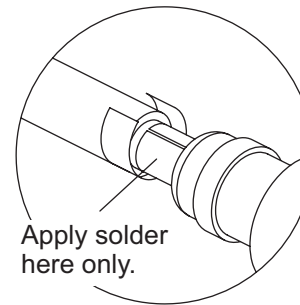
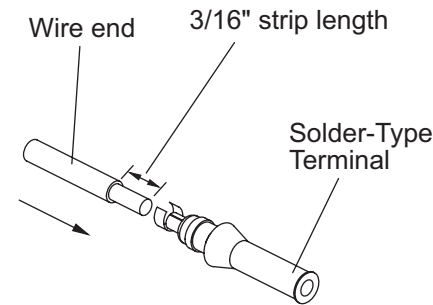

4. Using proper soldering techniques, solder the terminal to the wire. Apply solder only to the barrel of the terminal as illustrated.

## 14-PIN CONNECTOR PIN ASSIGNMENTS

Wire Color	Pin No.
Light Blue w/ Orange Stripe	1
Blue w/ Orange Stripe	2
Black w/ White Stripe	3
Light Green	4
Light Blue	5
White w/ Yellow Stripe	6
Brown w/ Red Stripe	7
Red w/ Yellow Stripe	8
Black w/ Orange Stripe	9
Brown w/ Green Stripe	10

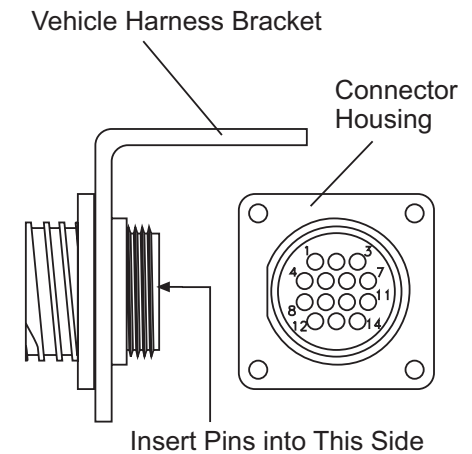

# THEORY OF OPERATION

## SNOWPLOW HEADLAMPS

The Isolation Module acts as an electrical hub, automatically directing vehicle power to the appropriate vehicle or snowplow lighting devices, while also supplying battery power to the snowplow control.

The vehicle high and low beams enter and exit the Isolation Module through positions 3 (left-side lighting) and position 4 (right-side lighting). Park, turn, and DRL signals also enter through positions 3 and 4.

When the snowplow is not attached to the vehicle, the signal passes through the normally closed relay contacts to the vehicle headlamps. During this time, the Isolation Module is inactive, placing no current draw on the vehicle's electrical system.

With the snowplow attached, the Isolation Module is still inactive until either of the two following conditions are met: the vehicle parking lights are turned on or the vehicle ignition switch is turned on.

Turning on the vehicle parking lights activates a series of relays, automatically transferring the vehicle high and low beams to the snowplow while supplying battery power directly to the snowplow parking lights. All snowplow lighting exits the Isolation Module through position 2.

Turning on the vehicle ignition switch energizes a snowplow control relay, supplying vehicle battery power directly to the control via the vehicle control harness. The vehicle ignition switch also supplies power to the vehicle turn signals. Activating the vehicle turn signals energizes turn signal relays, which supply vehicle battery power directly to the snowplow turn signals.

## SNOWPLOW DAYTIME RUNNING LIGHTS

Because Daytime Running Lamps (DRLs) are controlled differently on some vehicles, two Isolation Modules have been developed.

The standard Isolation Module transfers the DRL output to the snowplow lights when the vehicle ignition switch is on and the snowplow is attached.

When the Isolation Module designed for vehicles with dedicated DRL bulbs senses the vehicle in the DRL mode, a series of relays energize, placing the snowplow high beams in series. This Isolation Module does not turn off the vehicle DRLs.

## SNOWPLOW HYDRAULICS

The MVP® snowplow hydraulic system performs 10 blade movements.

All movements require the vehicle ignition (key) switch to be in the run or accessory position and the power to be activated on the snowplow cab control.

Nine of the ten hydraulic movements require energizing the electric motor, shifting solenoid cartridge spools, or activating P/O check valves. The tenth function, lower, does not energize the motor but requires shifting solenoid cartridge spools.

Power from the vehicle battery is supplied to the solenoid coils and the snowplow control via the Isolation Module. The solenoid cartridge valves operate in various combinations, directed by the cab control, to send hydraulic fluid to the snowplow lift and angle rams or back to the reservoir.

BLADE MOVEMENT	RAISE	LOWER	ANGLE RIGHT	ANGLE LEFT	VEE	SCOOP	RIGHT RETRACT	RIGHT EXTEND	LEFT RETRACT	LEFT EXTEND

# ELECTRICAL & HYDRAULIC SCHEMATICS

The following section contains hydraulic and electrical schematics to help explain how the hydraulic unit performs the different functions. A schematic is an abstract drawing showing the purpose of each of the components in the system. Each component is represented by a graphical symbol. The hydraulic and electrical legends describe each of the symbols used in the schematics for this guide.

The first two schematics show a general overview of the complete hydraulic and electrical systems. Other schematics highlight the flow of hydraulic fluid and electrical current for each function the hydraulic unit performs as well as the flow of electrical current for the snowplow and vehicle lights.

- Bold lines and gray lines represent the circuit being activated only.
- Shaded components are either activated or shifted from their normal position.

**NOTE: Left side = Driver side  
Right side = Passenger side**

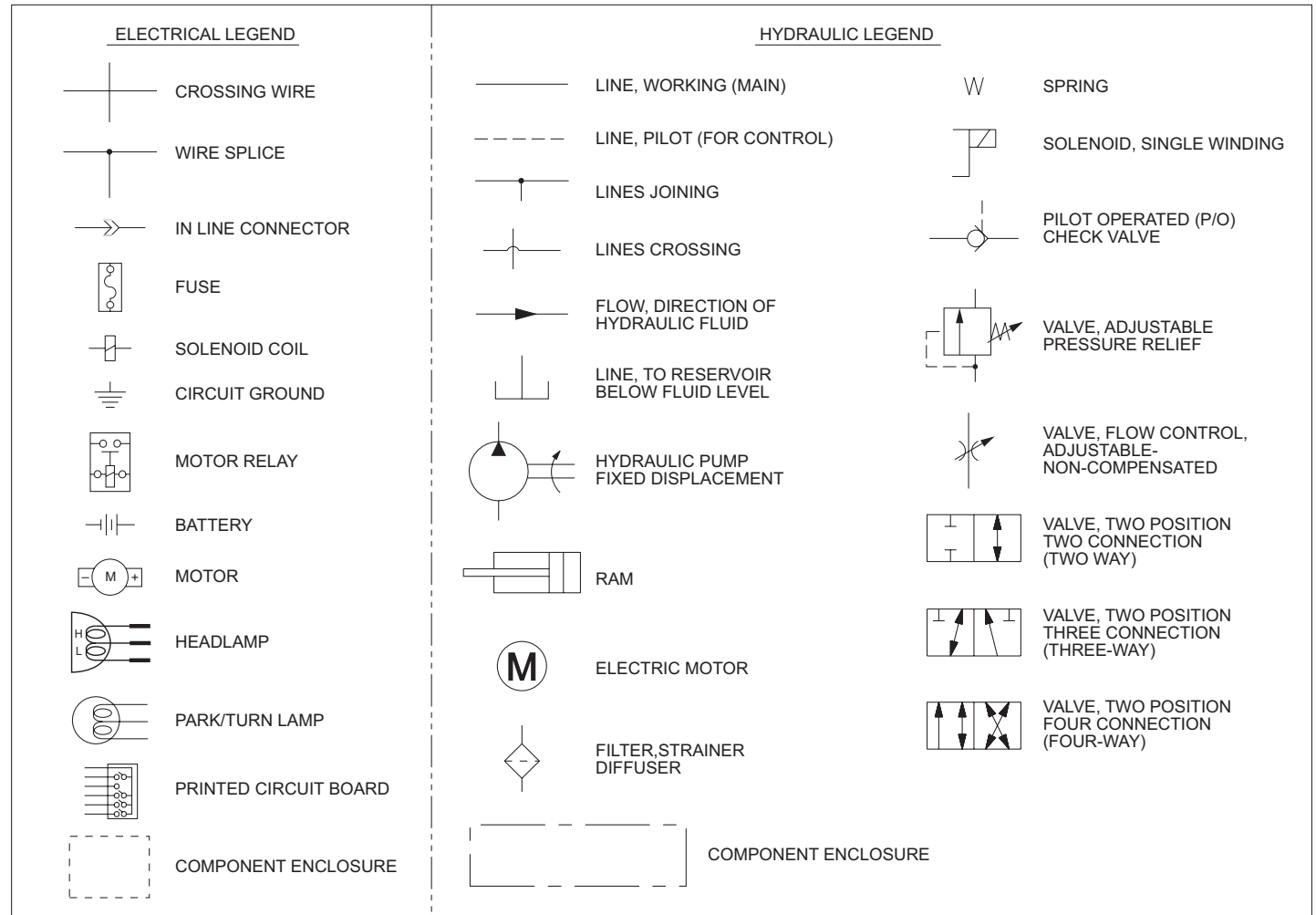

Wire Color Code							
BLK	Black	BRN	Brown	LTGRN	Light Green	TAN	Tan
BLK/ORN	Black w/ Orange	BRN/GRN	Brown w/ Green	LTBLU/ORN	Light Blue w/ Orange	VIO	Violet
BLK/RED	Black w/ Red	BRN/RED	Brown w/ Red	ORN	Orange	WHT	White
BLK/WHT	Black w/ White	GRN	Green	PNK	Pink	WHT/YEL	White w/ Yellow
BLU	Blue	GRY	Gray	PUR	Purple	YEL	Yellow
BLU/ORN	Blue w/ Orange	LTBLU	Light Blue	RED	Red		

# ELECTRICAL SCHEMATIC

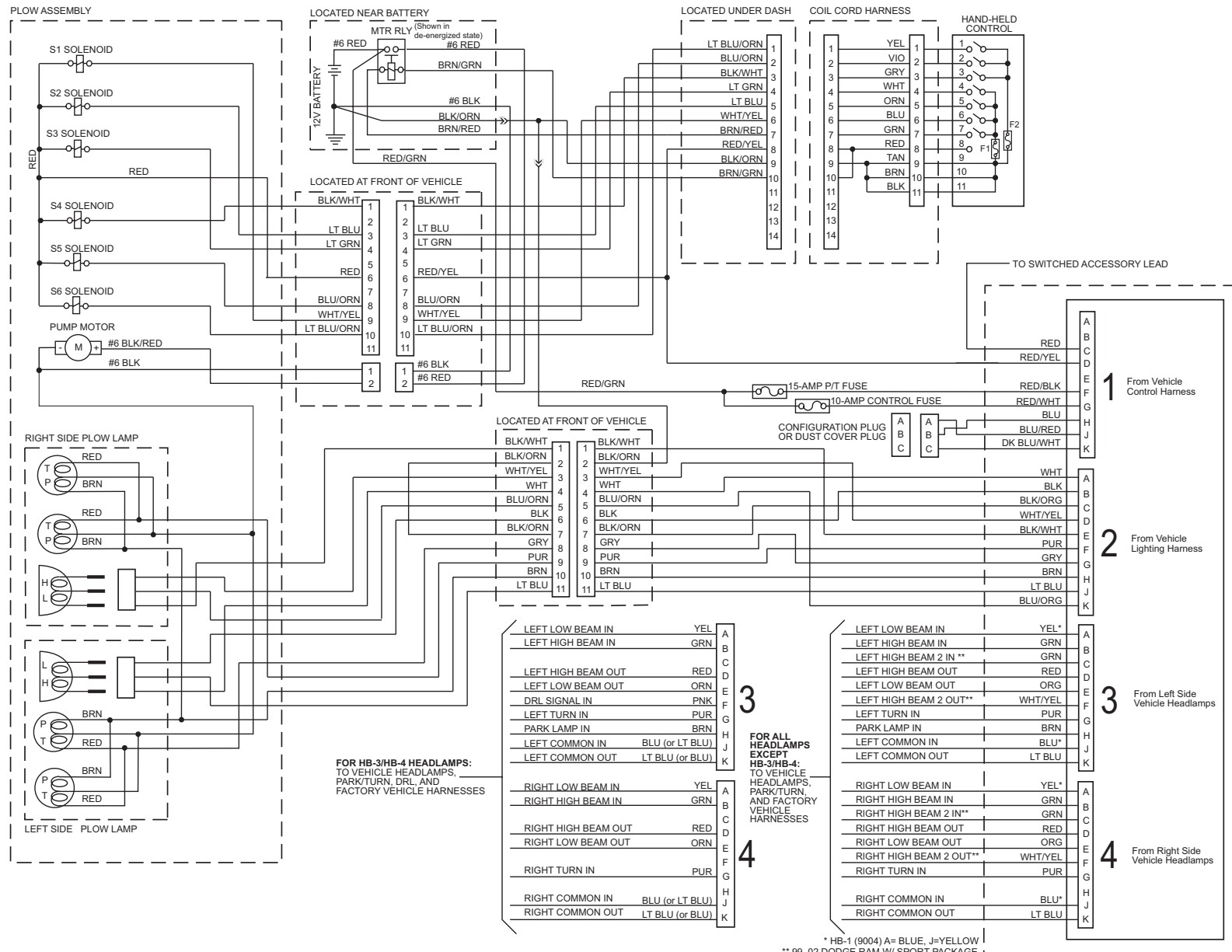

# HYDRAULIC SCHEMATIC

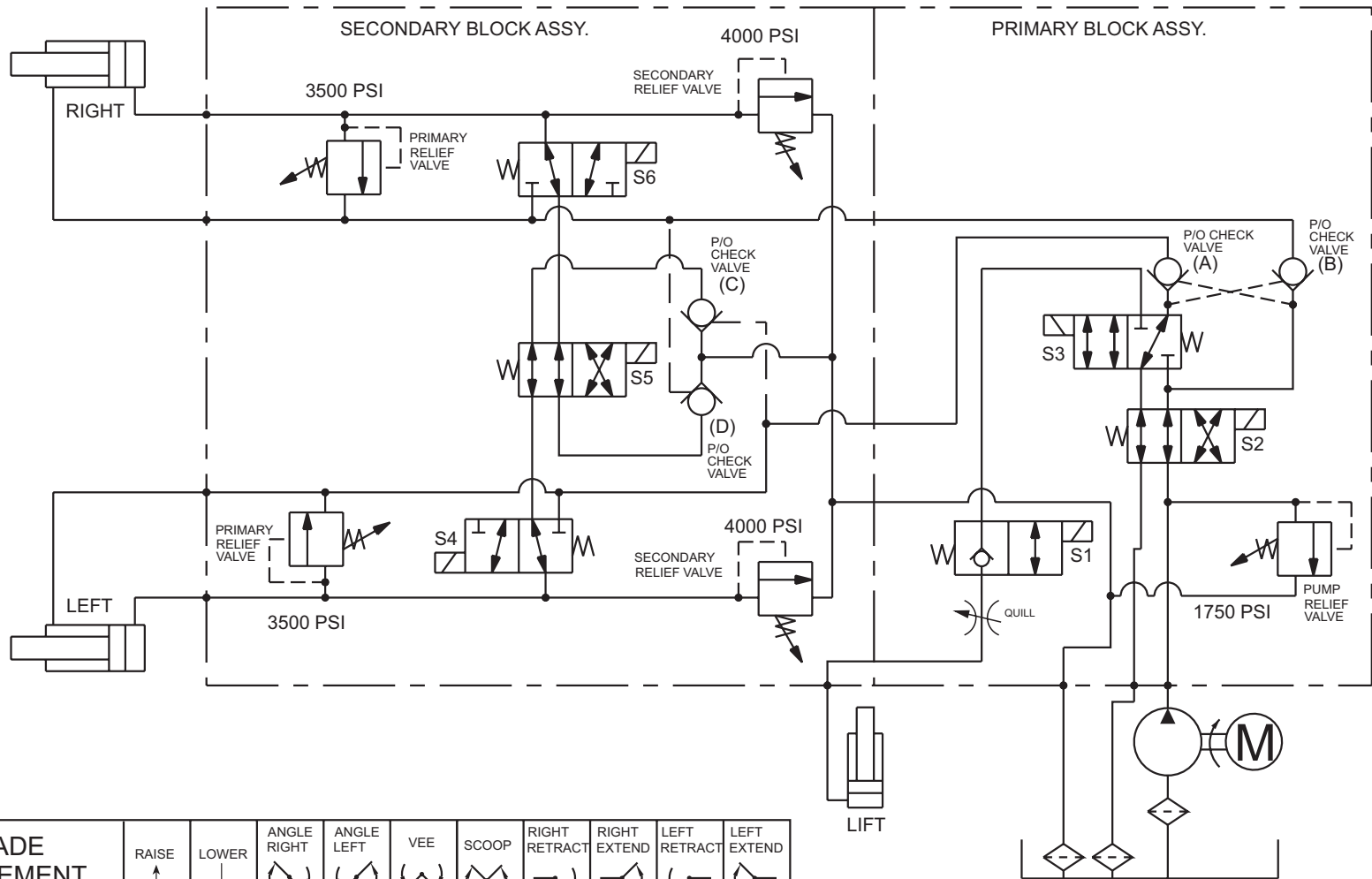

BLADE MOVEMENT		RAISE ↑	LOWER ↓	ANGLE RIGHT 	ANGLE LEFT 	VEE 	SCOOP 	RIGHT RETRACT 	RIGHT EXTEND 	LEFT RETRACT 	LEFT EXTEND 
MOTOR	M	ON		ON	ON	ON	ON	ON	ON	ON	ON
SV08-2004	S1		ON								
SV08-40	S2	ON			ON					ON	ON
SV08-43	S3	ON	ON			ON	ON				
SV08-30	S4						ON				ON
SV08-40	S5			ON	ON						
SV08-30	S6						ON		ON		

# RAISE – ELECTRICAL

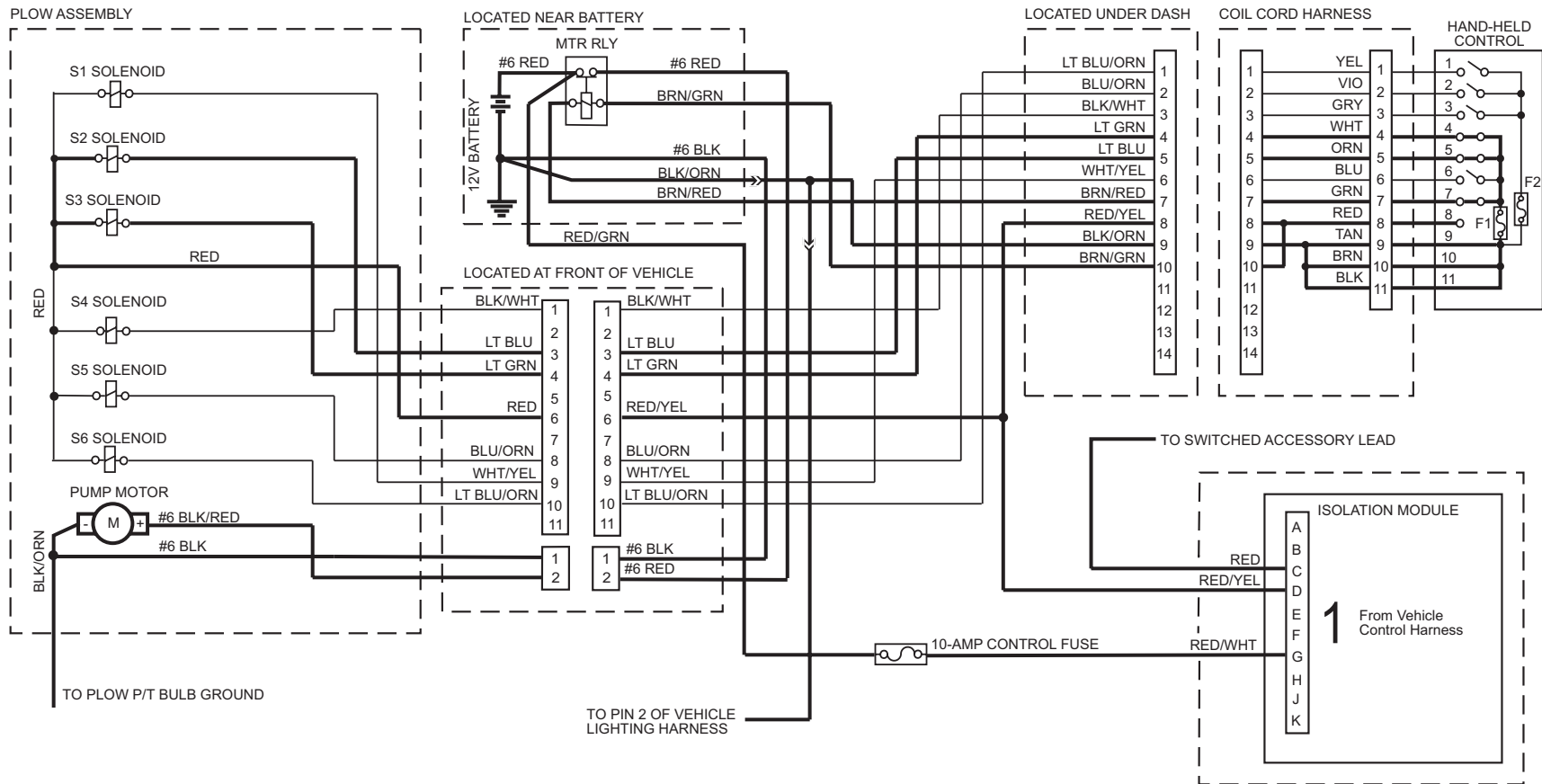







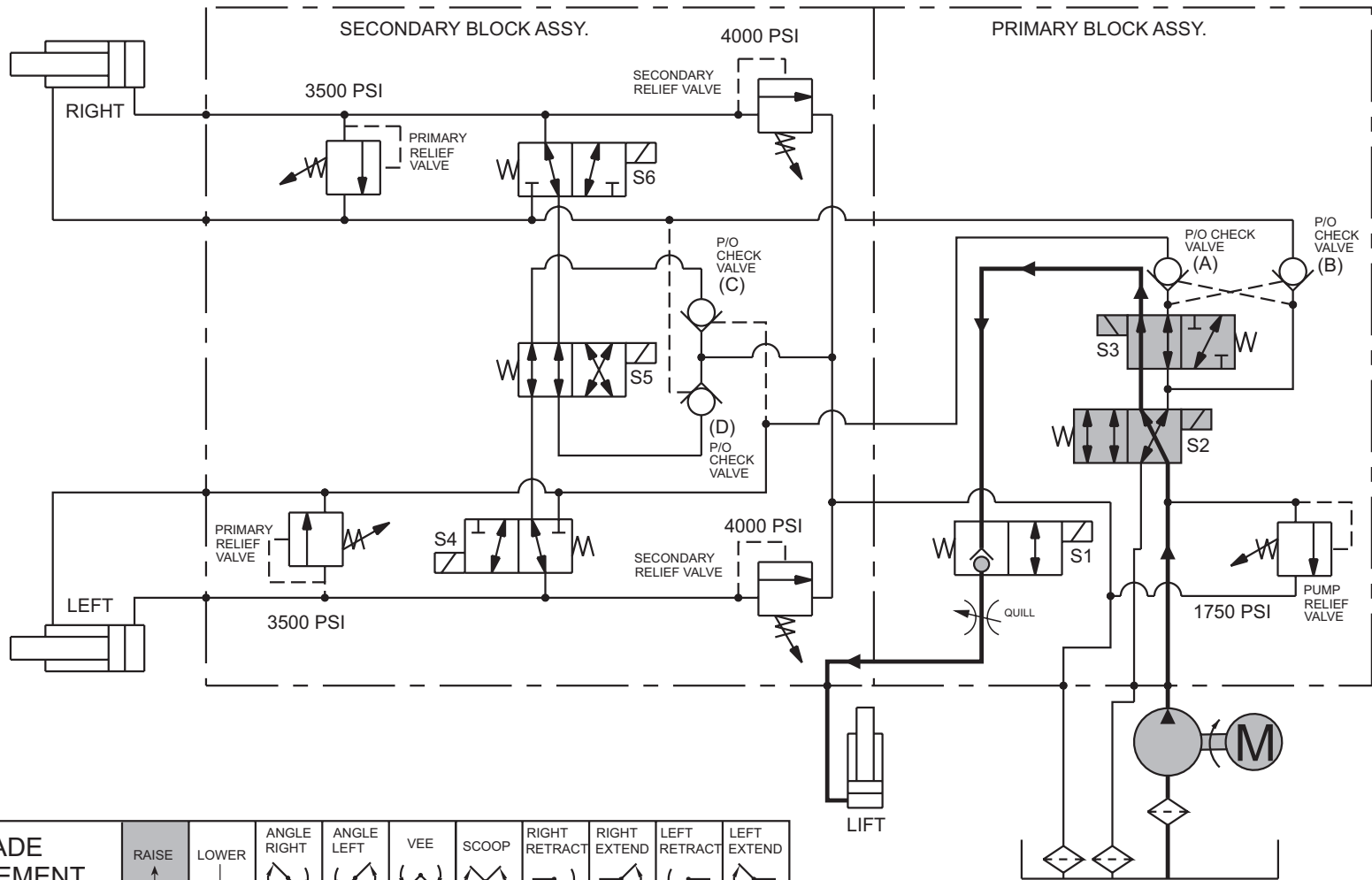

## System Response

1. By pressing the control button, the circuit board inside the cab control completes the ground path for the electrical circuit.
2. Electrical current flows through the motor relay, activating the pump motor, and solenoid cartridge valves S2 & S3, shifting both spools.
3. Hydraulic fluid from the pump flows through solenoid cartridge valves S2 & S3, through the internal check valve in solenoid cartridge valve S1 into the base end of the lift ram causing it to extend.

# RAISE – HYDRAULIC



BLADE MOVEMENT		RAISE ↑	LOWER ↓	ANGLE RIGHT 	ANGLE LEFT 	VEE 	SCOOP 	RIGHT RETRACT 	RIGHT EXTEND 	LEFT RETRACT 	LEFT EXTEND 
MOTOR	M	ON		ON	ON	ON	ON	ON	ON	ON	ON
SV08-2004	S1		ON								
SV08-40	S2	ON			ON					ON	ON
SV08-43	S3	ON	ON			ON	ON				
SV08-30	S4						ON				ON
SV08-40	S5			ON	ON						
SV08-30	S6						ON	ON			

# LOWER – ELECTRICAL

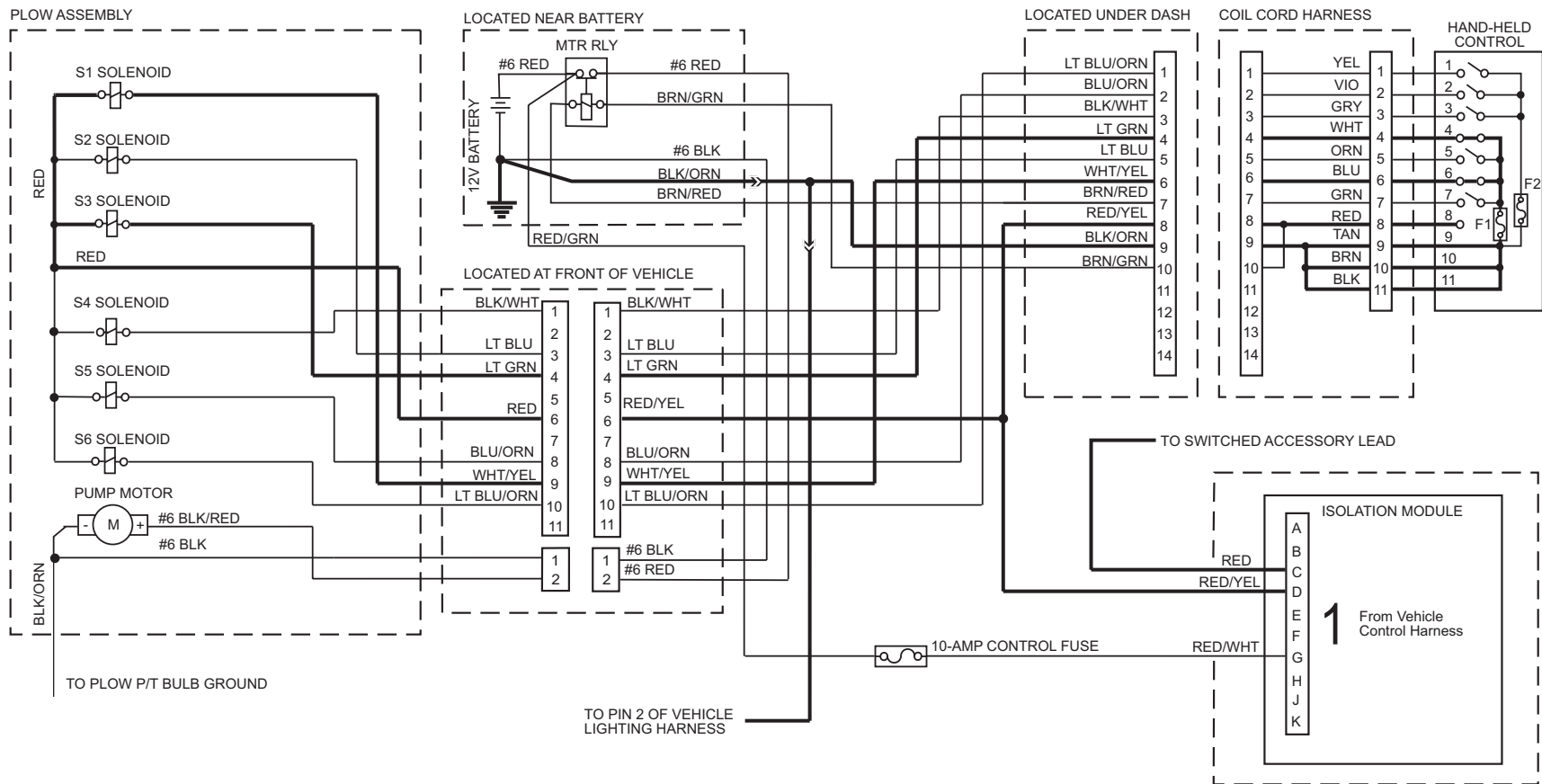







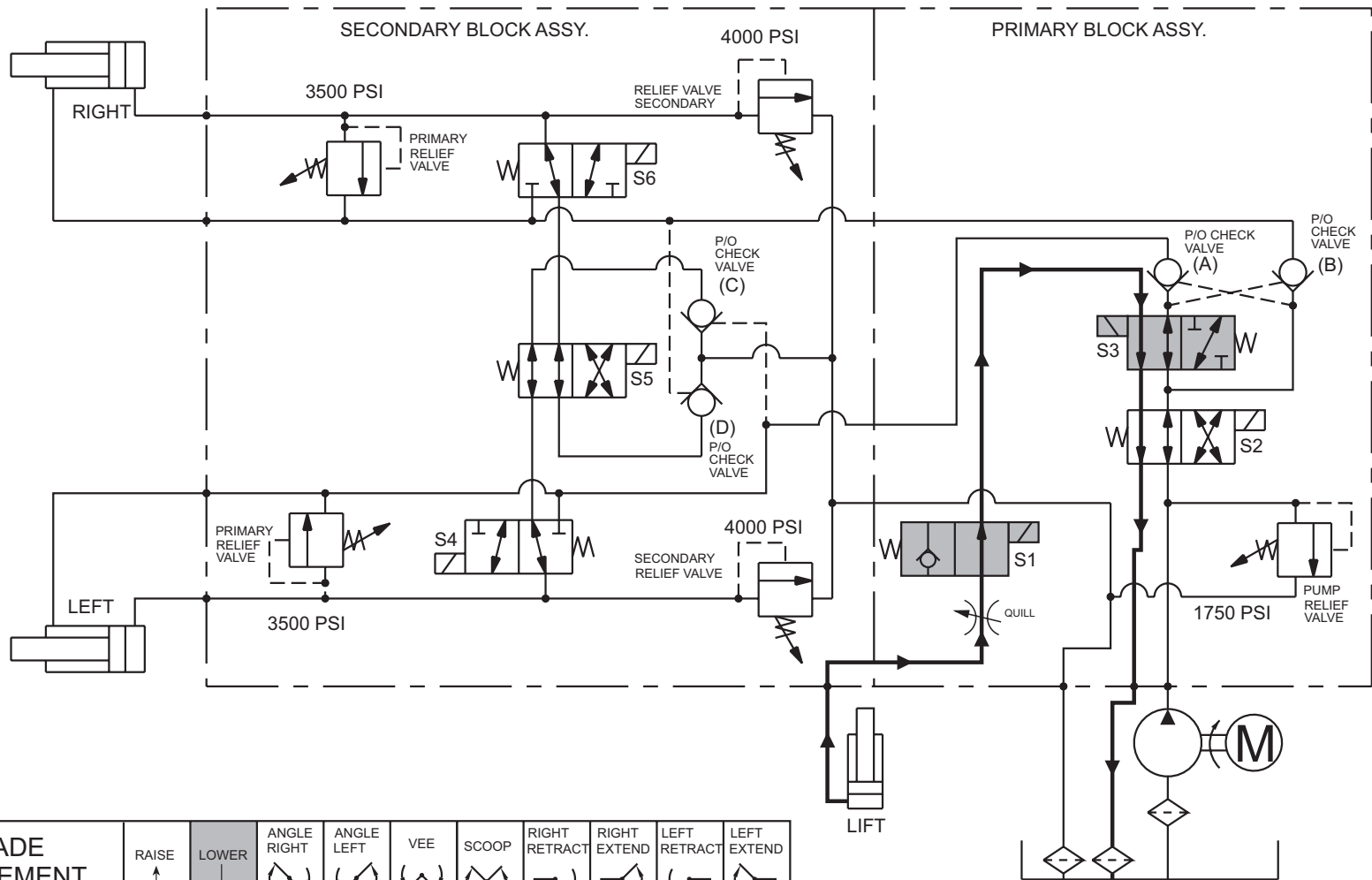

## System Response

1. By pressing the control button, the circuit board inside the cab control completes the ground path for the electrical circuit.
2. Electrical current flows through solenoid cartridge valves S1 & S3 shifting both spools.
3. The weight of the plow forces the lift ram to retract. The retracting lift ram pushes the hydraulic fluid out of its base end, through solenoid cartridge valves S1 & S3 & S2, and back to the reservoir.



# LOWER – HYDRAULIC



BLADE MOVEMENT		RAISE ↑	LOWER ↓	ANGLE RIGHT 	ANGLE LEFT 	VEE 	SCOOP 	RIGHT RETRACT 	RIGHT EXTEND 	LEFT RETRACT 	LEFT EXTEND 
MOTOR	M	ON		ON	ON	ON	ON	ON	ON	ON	ON
SV08-2004	S1		ON								
SV08-40	S2	ON			ON					ON	ON
SV08-43	S3	ON	ON			ON	ON				
SV08-30	S4						ON				ON
SV08-40	S5			ON	ON						
SV08-30	S6						ON		ON		

# ANGLE RIGHT – ELECTRICAL

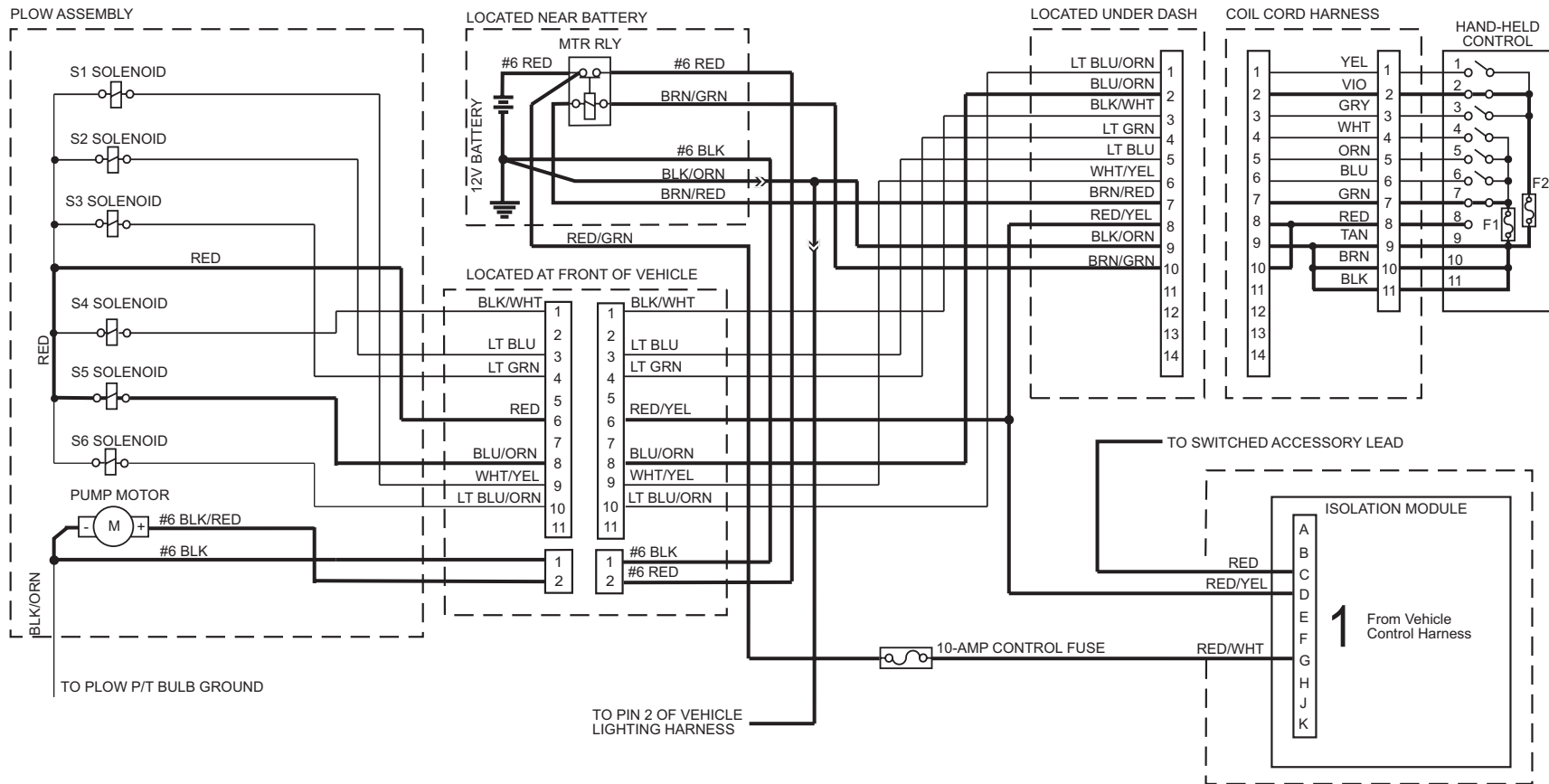







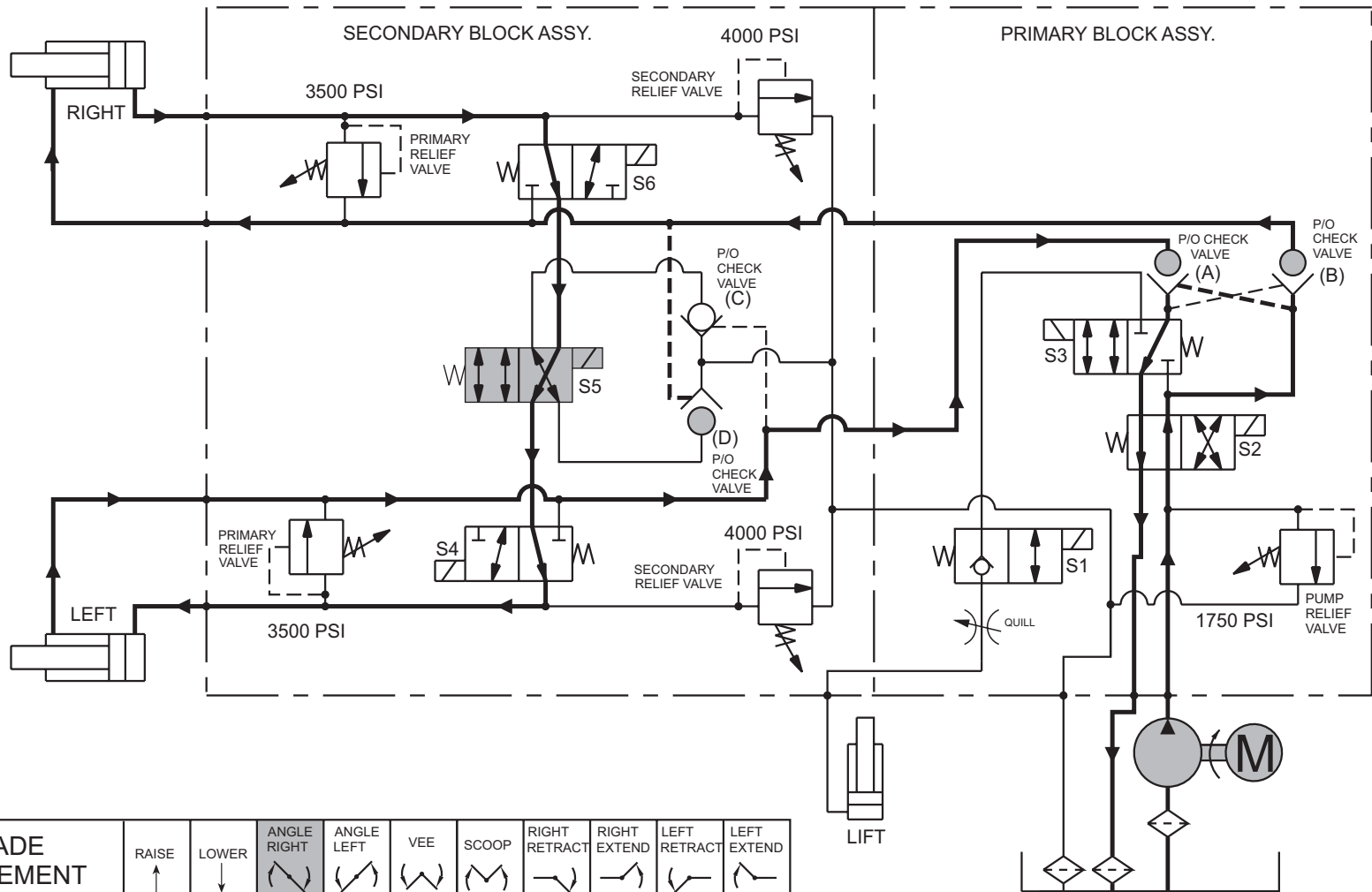

## System Response

- By pressing the control button, the circuit board inside the cab control completes the ground path for the electrical circuit.
- Electrical current flows through the motor relay, activating the pump motor, and solenoid cartridge valve S5, shifting its spool.
- Hydraulic fluid from the pump flows through solenoid cartridge valve S2, P/O check valve (B) and into the rod end of the right ram causing it to retract.
- Pressure within the hydraulic circuit causes P/O check valves (A) & (D) to open.
- The retracting right ram pushes the hydraulic fluid out of its base end, through solenoid cartridge valves S6 & S5 & S4 and into the base end of the left ram causing it to extend.
- The extending left ram pushes the hydraulic fluid out of its rod end, through P/O check valve (A), solenoid cartridge valves S3 & S2 and back to the reservoir.

# ANGLE RIGHT – HYDRAULIC



BLADE MOVEMENT		RAISE ↑	LOWER ↓	ANGLE RIGHT 	ANGLE LEFT 	VEE 	SCOOP 	RIGHT RETRACT 	RIGHT EXTEND 	LEFT RETRACT 	LEFT EXTEND 
MOTOR	M	ON		ON	ON	ON	ON	ON	ON	ON	ON
SV08-2004	S1		ON		ON					ON	ON
SV08-40	S2	ON			ON					ON	ON
SV08-43	S3	ON	ON			ON	ON				
SV08-30	S4						ON				ON
SV08-40	S5			ON	ON						
SV08-30	S6						ON	ON			

# ANGLE LEFT – ELECTRICAL

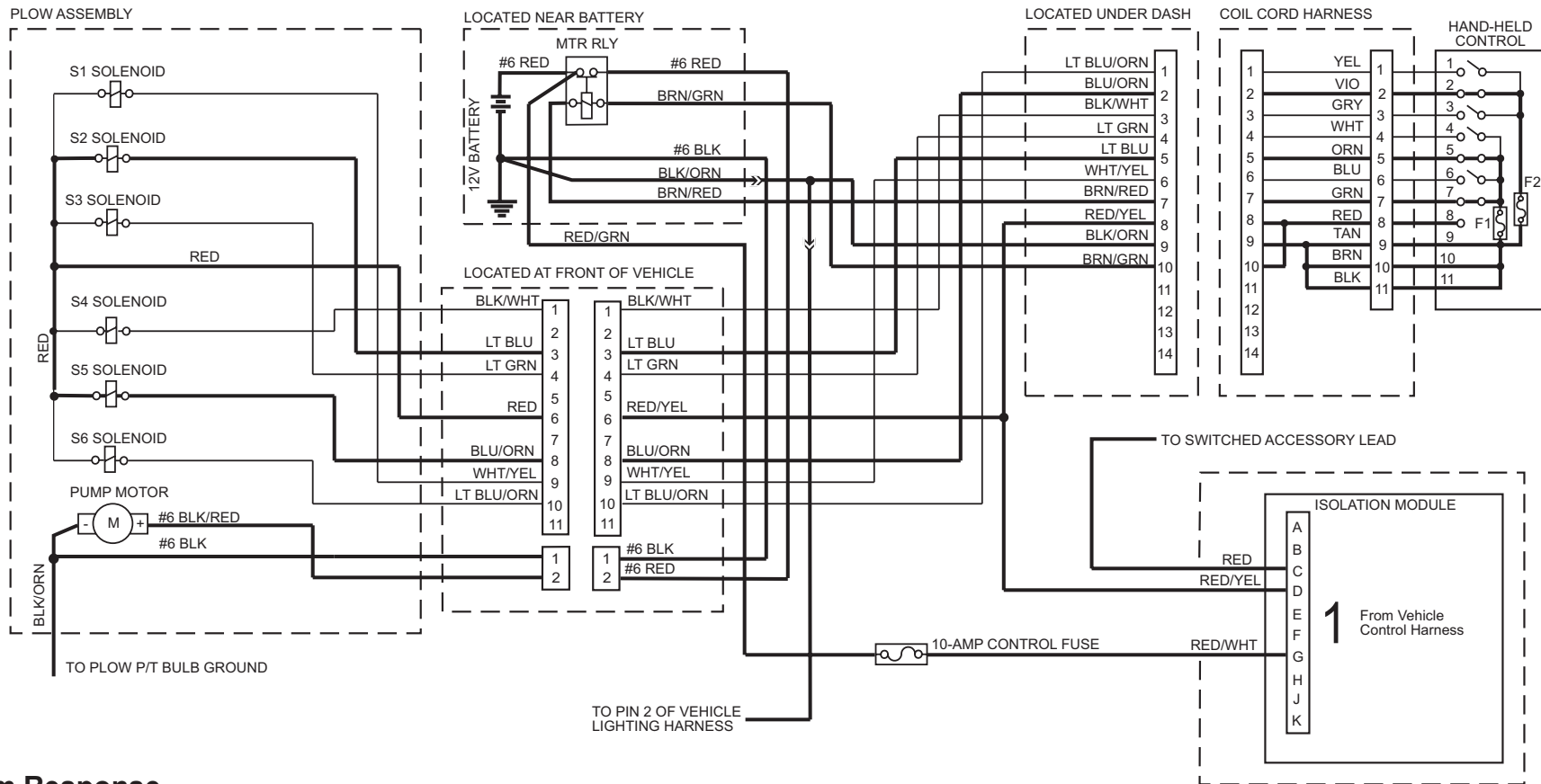







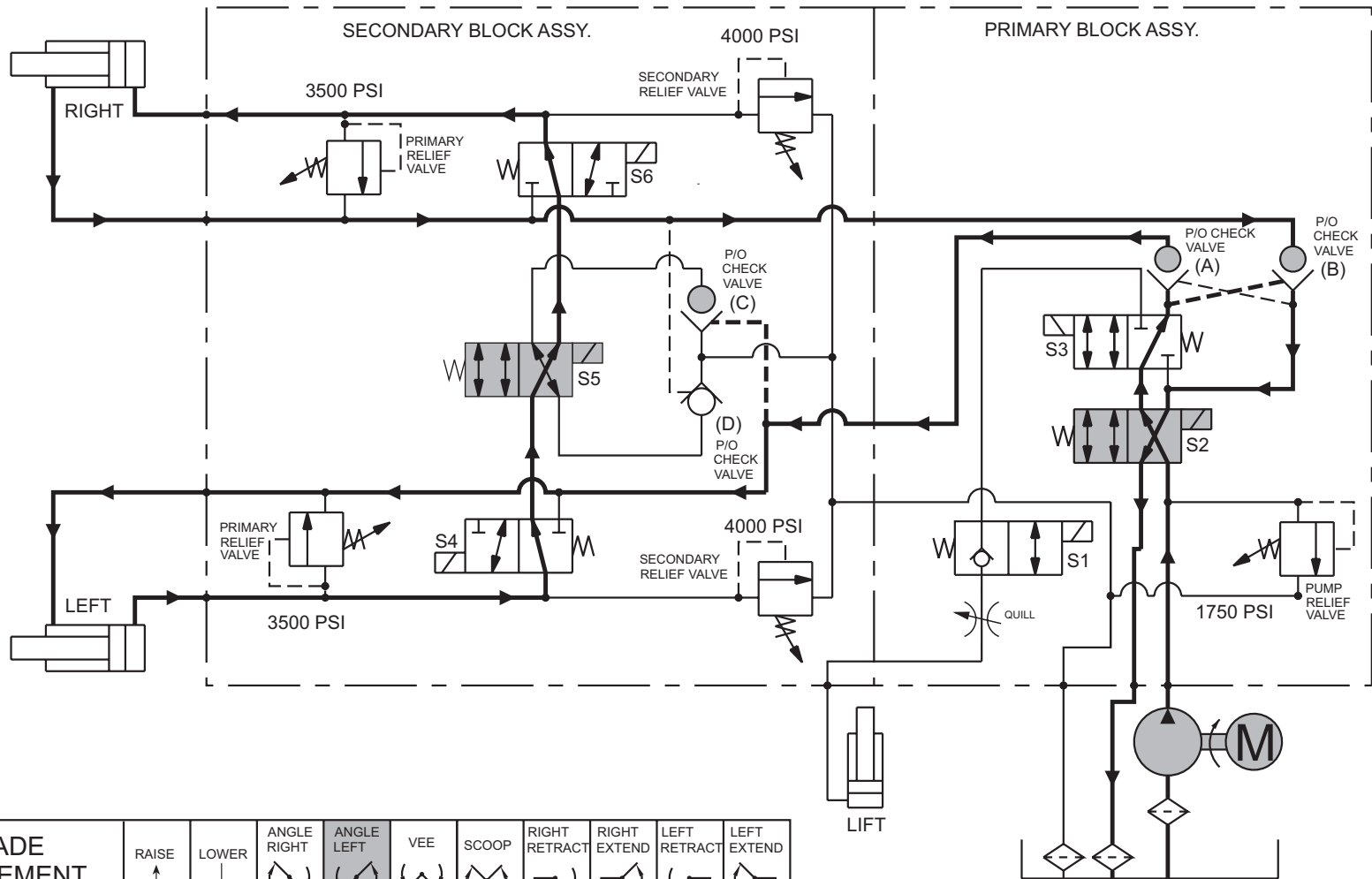

## System Response

1. By pressing the control button, the circuit board inside the cab control completes the ground path for the electrical circuit.
2. Electrical current flows through the motor relay, activating the pump motor, and solenoid cartridge valves S2 & S5, shifting both spools.
3. Hydraulic fluid from the pump flows through solenoid cartridge valves S2 & S3, P/O check valve (A) and into the rod end of the left ram causing it to retract.
4. Pressure within the hydraulic circuit causes P/O check valves (B) & (C) to open.
5. The retracting left ram pushes the hydraulic fluid out of its base end, through solenoid cartridge valves S4 & S5 & S6 and into the base end of the right ram causing it to extend.
6. The extending right ram pushes the hydraulic fluid out of its rod end, through P/O check valve (B), solenoid cartridge valve S2 and back to the reservoir.

# ANGLE LEFT – HYDRAULIC



BLADE MOVEMENT		RAISE ↑	LOWER ↓	ANGLE RIGHT 	ANGLE LEFT 	VEE 	SCOOP 	RIGHT RETRACT 	RIGHT EXTEND 	LEFT RETRACT 	LEFT EXTEND 
MOTOR	M	ON		ON	ON	ON	ON	ON	ON	ON	ON
SV08-2004	S1		ON								
SV08-40	S2	ON			ON					ON	ON
SV08-43	S3	ON	ON			ON	ON				
SV08-30	S4						ON				ON
SV08-40	S5			ON	ON						
SV08-30	S6						ON		ON		

# VEE – ELECTRICAL

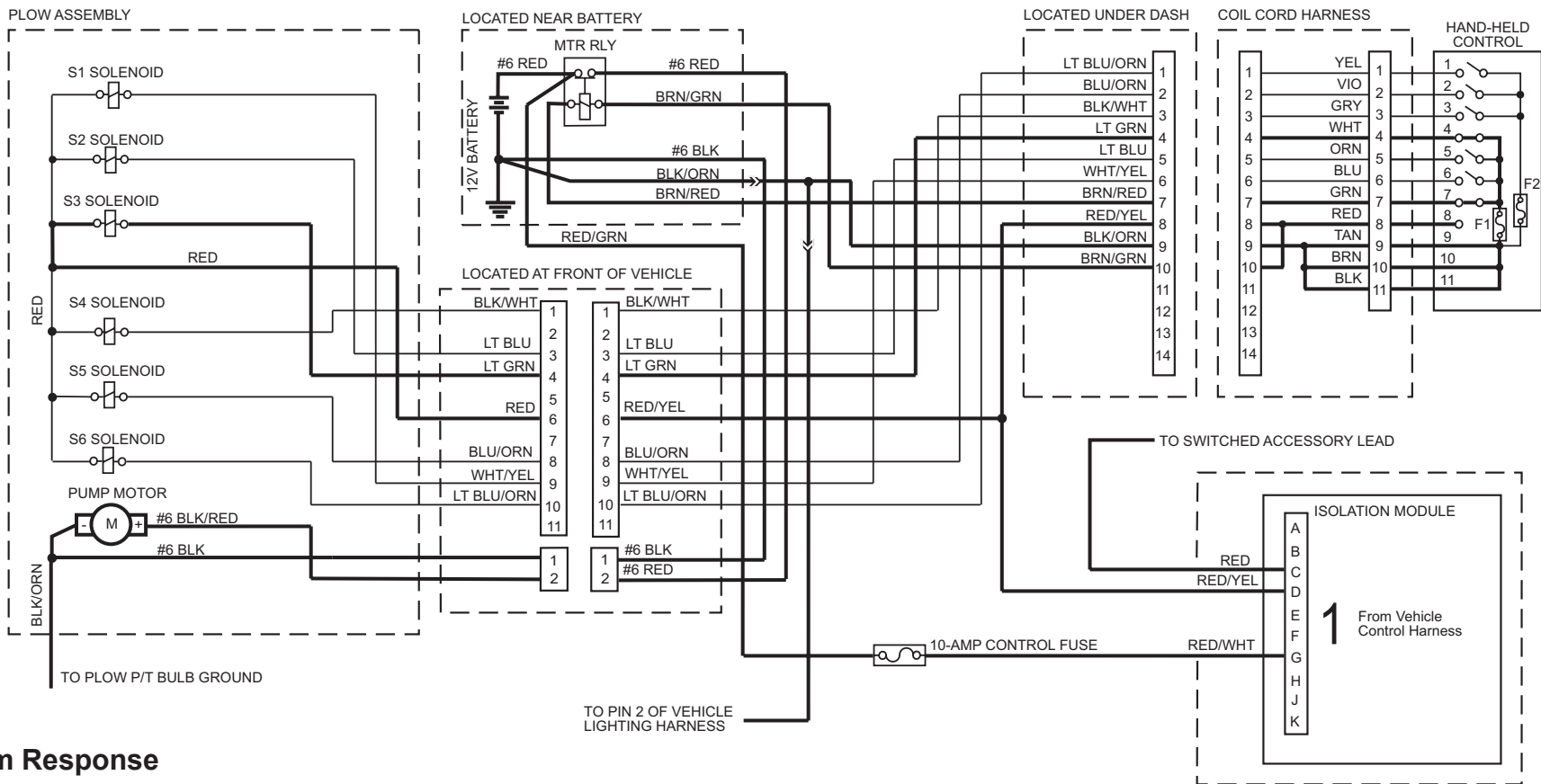

## System Response

- By pressing the control button, the circuit board inside the cab control completes the ground path for the electrical circuit.
- Electrical current flows through the motor relay, activating the pump motor, and solenoid cartridge valve S3, shifting its spool.
- Hydraulic fluid from the pump flows through solenoid cartridge valve S2 and into two separate hydraulic circuits.
- Half of the fluid flows through P/O check valve (B) and into the rod end of the right ram causing it to retract.
- The other half of the fluid flows through solenoid cartridge valve S3, P/O check valve (A) and into the rod end of the left ram causing it to retract.
- Pressure within the hydraulic circuit causes P/O check valves (C) & (D) to open.
- The retracting right ram pushes the hydraulic fluid out of its base end, through solenoid cartridge valves S6 & S5, P/O check valve (D) and back to the reservoir.
- The retracting left ram pushes the hydraulic fluid out of its base end, through solenoid cartridge valves S4 & S5, through P/O check valve (C) and back to the reservoir.

# VEE – HYDRAULIC

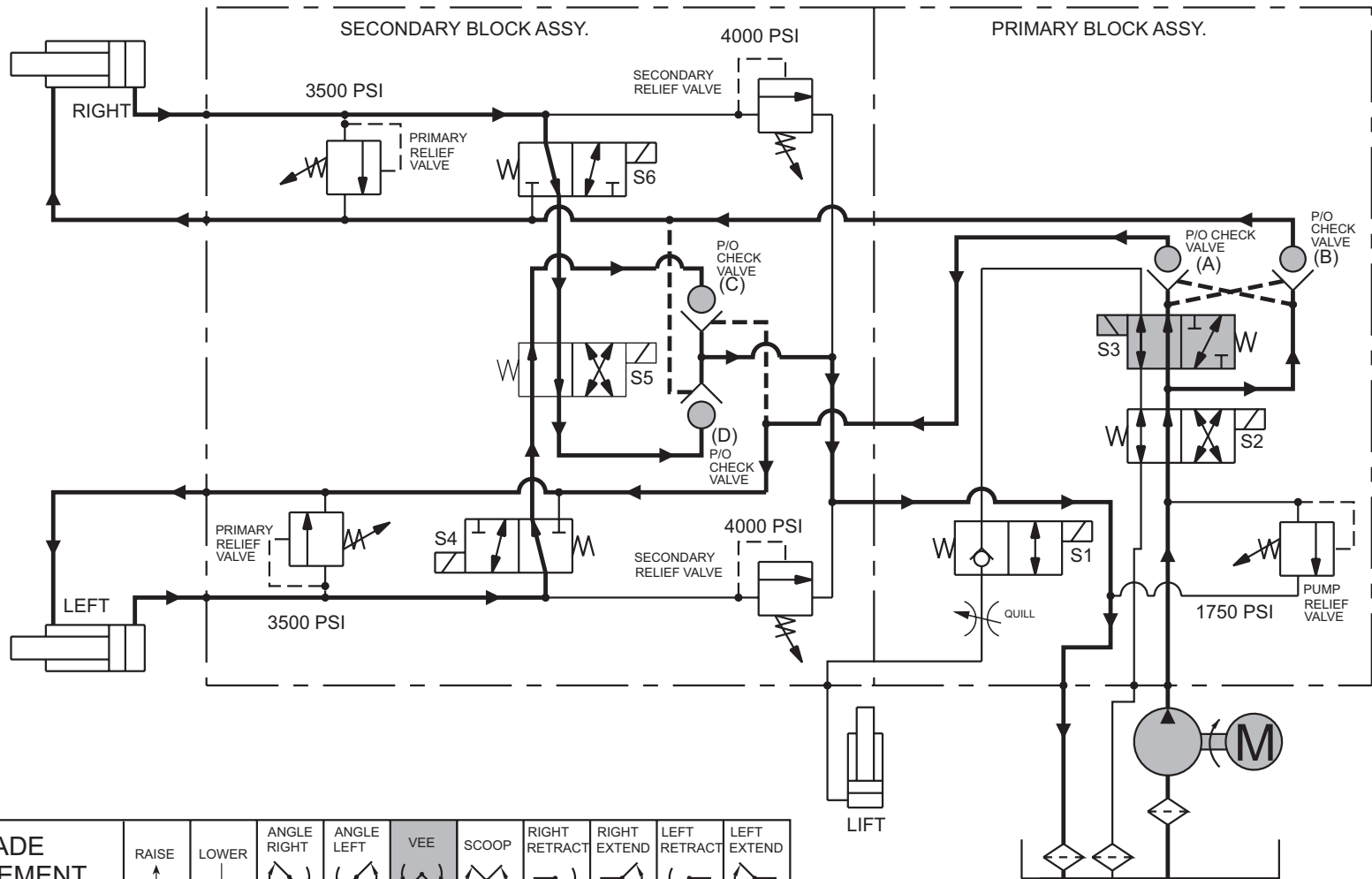

BLADE MOVEMENT		RAISE ↑	LOWER ↓	ANGLE RIGHT 	ANGLE LEFT 	VEE 	SCOOP 	RIGHT RETRACT 	RIGHT EXTEND 	LEFT RETRACT 	LEFT EXTEND 
MOTOR	M	ON		ON	ON	ON	ON	ON	ON	ON	ON
SV08-2004	S1		ON								
SV08-40	S2	ON			ON					ON	ON
SV08-43	S3	ON	ON			ON	ON				
SV08-30	S4						ON				ON
SV08-40	S5			ON	ON						
SV08-30	S6						ON	ON			

# SCOOP – ELECTRICAL

## System Response

1. By pressing the control button, the circuit board inside the cab control completes the ground path for the electrical circuit.

2. Electrical current flows through the motor relay, activating the pump motor, and solenoid cartridge valves S3 & S4 & S6, shifting the three spools.

3. Hydraulic fluid from the pump flows through solenoid cartridge valve S2 and into two separate hydraulic circuits.

4. Half of the fluid flows through P/O check valve (B), solenoid cartridge valve S6 and into the base end of the right ram causing it to extend. The extending right ram pushes the hydraulic fluid out of its rod end. This fluid mixes with the hydraulic fluid from the pump, passes through solenoid cartridge valve S6 and into the base end of the extending right ram. This is called a *regenerative hydraulic circuit*. Even though both sides of

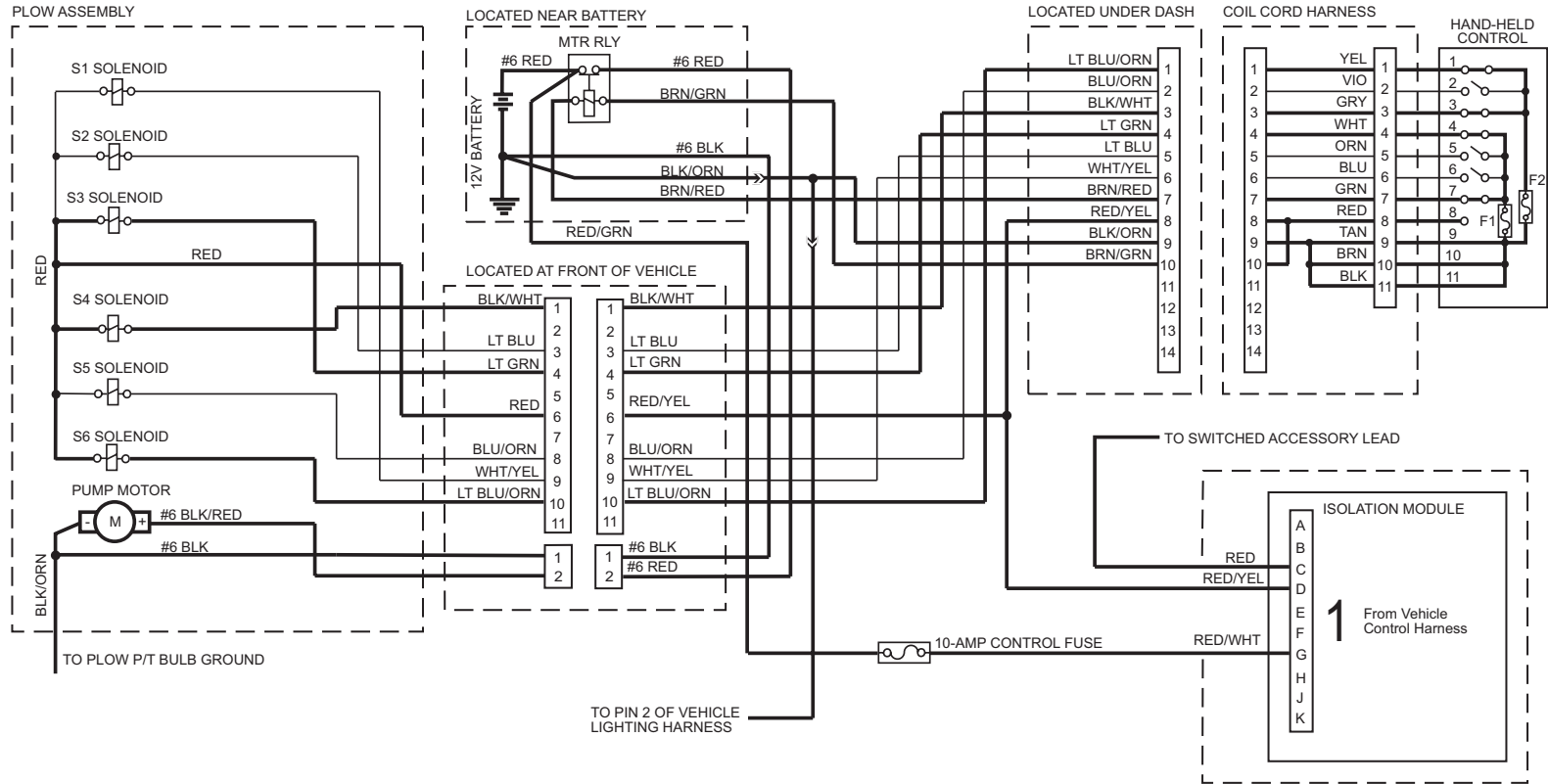

*the ram piston will experience the same hydraulic pressure, the ram will extend due to unequal force. The difference in area between the base end and rod end of the ram piston creates a greater force on the base end which extends the ram.*  
 $Force = Pressure \times Surface Area.$

5. The other half of the fluid flows through solenoid cartridge valve S3, P/O check valve (A), solenoid cartridge valve S4 and into the base end of the left ram causing it to extend. The extending left ram pushes the hydraulic fluid out of its rod end. This fluid mixes with the hydraulic fluid from the pump,

passes through solenoid cartridge valve S4 and into the base end of the extending left ram. This is also a *regenerative hydraulic circuit*.

6. Pressure within the hydraulic circuit causes P/O check valves (C) & (D) to open.



# SCOOP – HYDRAULIC

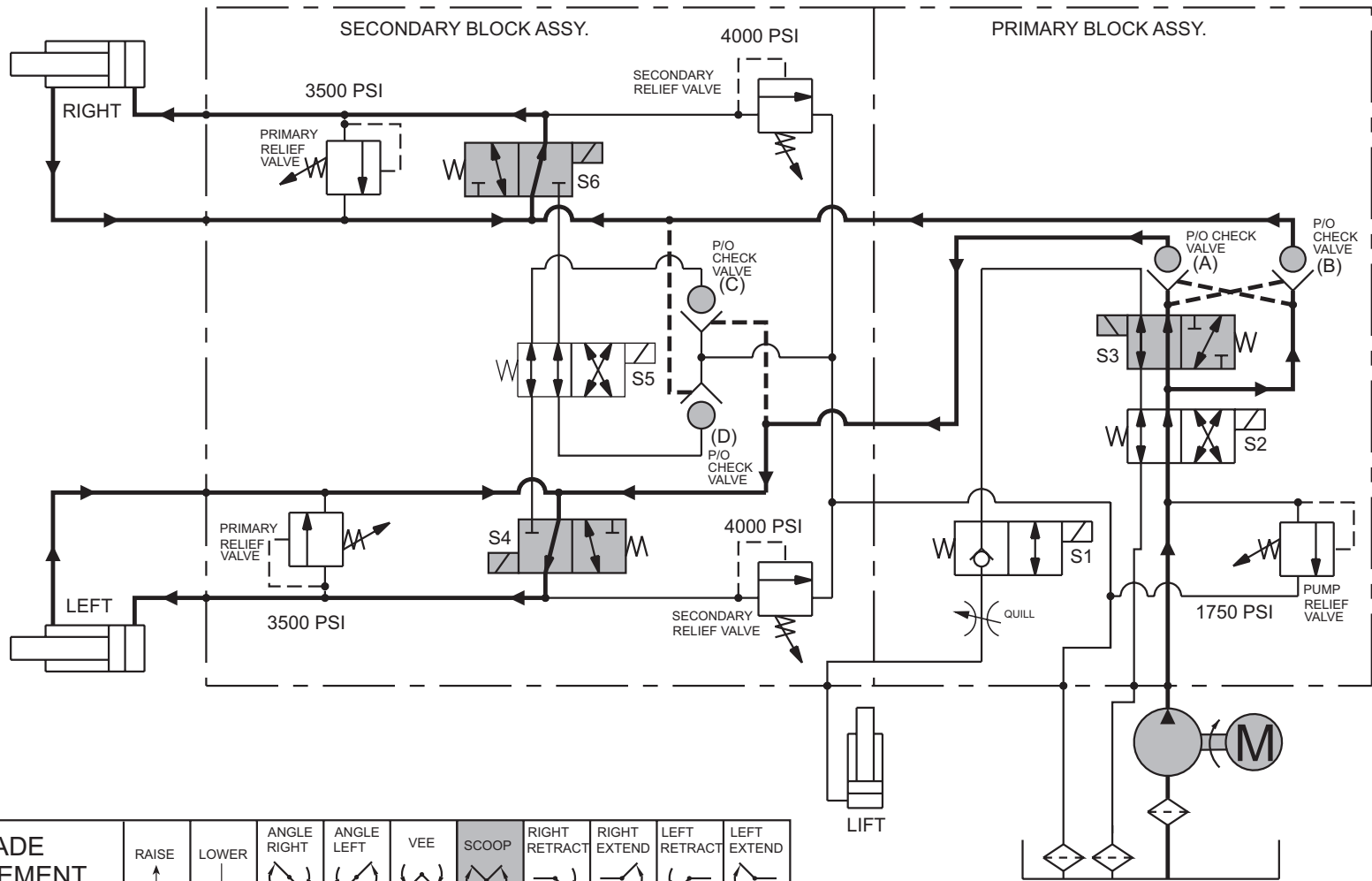

BLADE MOVEMENT		RAISE ↑	LOWER ↓	ANGLE RIGHT 	ANGLE LEFT 	VEE 	SCOOP 	RIGHT RETRACT 	RIGHT EXTEND 	LEFT RETRACT 	LEFT EXTEND 
MOTOR	M	ON		ON	ON	ON	ON	ON	ON	ON	ON
SV08-2004	S1	ON									
SV08-40	S2	ON			ON					ON	ON
SV08-43	S3	ON	ON			ON	ON				
SV08-30	S4						ON				ON
SV08-40	S5			ON	ON						
SV08-30	S6						ON		ON		

# RIGHT RETRACT – ELECTRICAL

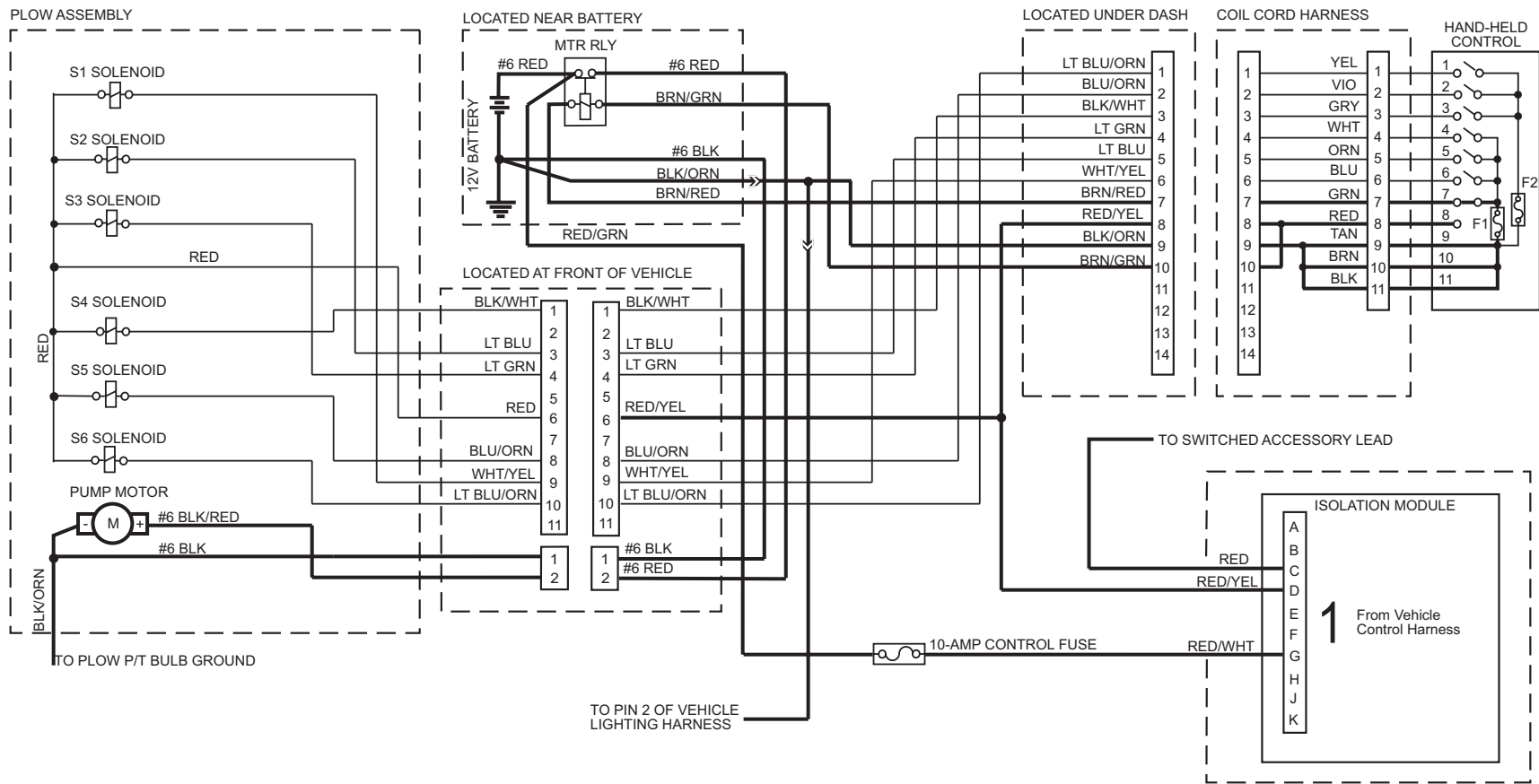

## System Response

1. By pressing the control button, the circuit board inside the cab control completes the ground path for the electrical circuit.
2. Electrical current flows through the motor relay activating the pump motor.
3. Hydraulic fluid from the pump flows through solenoid cartridge valve S2, P/O check valve (B) and into the rod end of the right ram causing it to retract.
4. Pressure within the hydraulic circuit causes P/O check valves (A) & (D) to open.
5. The retracting right ram pushes the hydraulic fluid out of its base end, through solenoid cartridge valves S6 & S5, P/O check valve (D) and back to the reservoir.

# RIGHT RETRACT – HYDRAULIC

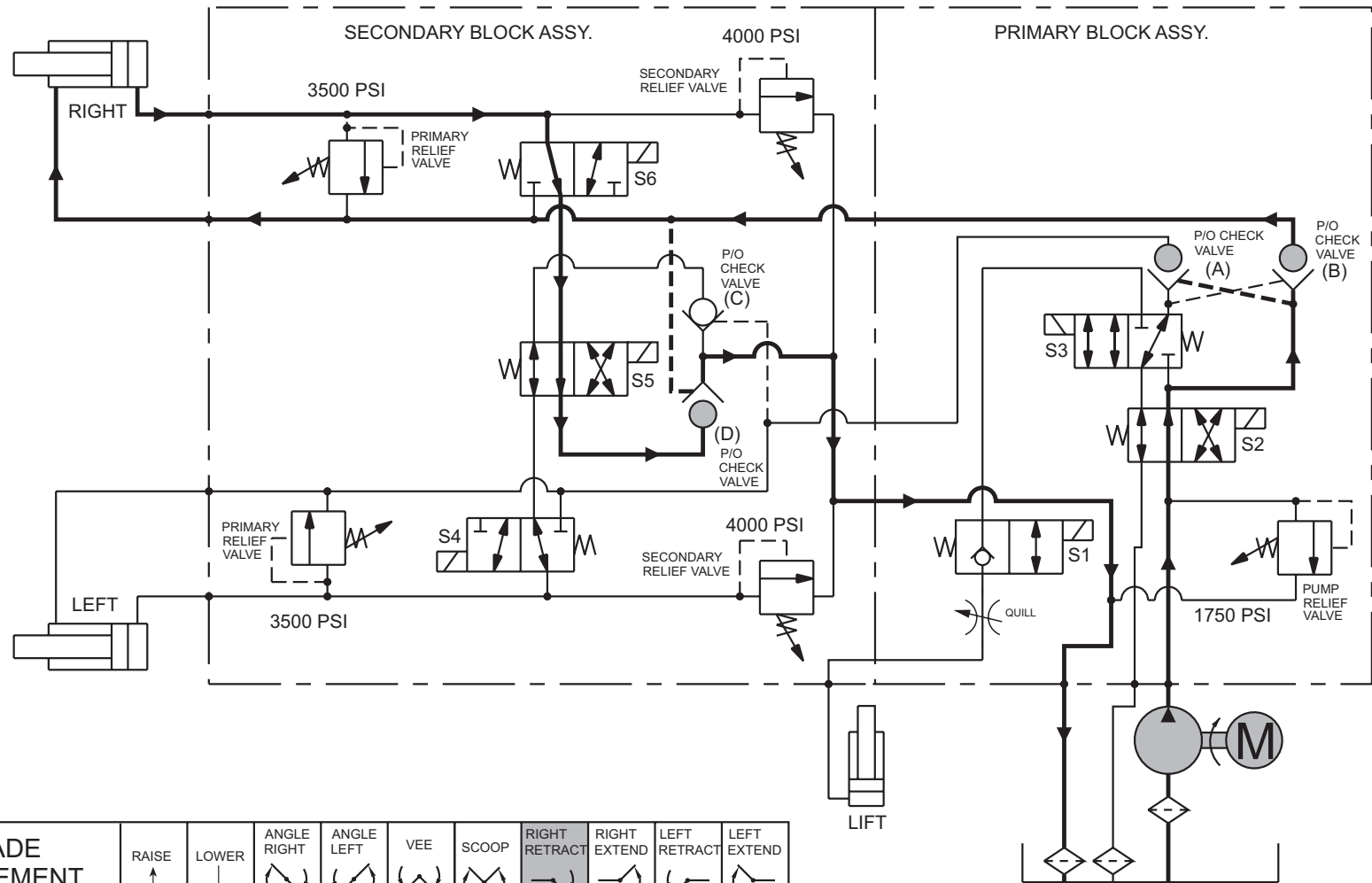

BLADE MOVEMENT		RAISE ↑	LOWER ↓	ANGLE RIGHT 	ANGLE LEFT 	VEE 	SCOOP 	RIGHT RETRACT 	RIGHT EXTEND 	LEFT RETRACT 	LEFT EXTEND 
MOTOR	M	ON		ON	ON	ON	ON	ON	ON	ON	ON
SV08-2004	S1		ON								
SV08-40	S2	ON			ON					ON	ON
SV08-43	S3	ON	ON			ON	ON				
SV08-30	S4						ON				ON
SV08-40	S5			ON	ON						
SV08-30	S6						ON	ON			

# RIGHT EXTEND – ELECTRICAL

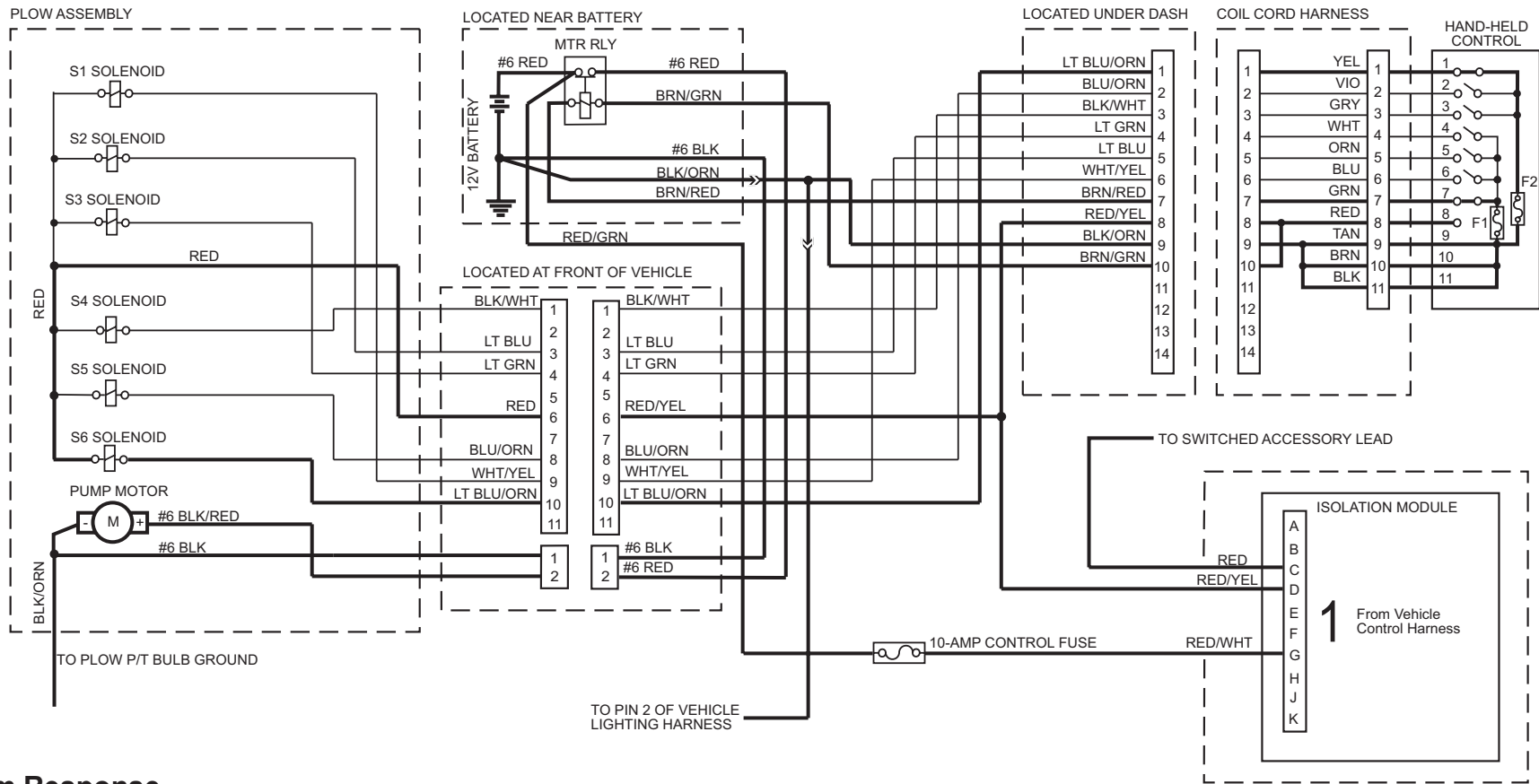

## System Response

- By pressing the control button, the circuit board inside the cab control completes the ground path for the electrical circuit.
- Electrical current flows through the motor relay, activating the pump motor, and solenoid cartridge valve S6, shifting its spool.
- Hydraulic fluid from the pump flows through solenoid cartridge valve S2, P/O check valve (B), solenoid cartridge valve S6 and into the base end of the right ram causing it to extend.
- The extending right ram pushes the hydraulic fluid out of its rod end. This fluid mixes with the hydraulic fluid from the pump, passes through solenoid cartridge valve S6 and into the base end of the extending right ram. This is called a *regenerative hydraulic circuit*. Even though both sides of the ram piston experience the same hydraulic pressure, the ram extends due to unequal force. The difference in area between the base end and rod end of the ram piston creates a greater force on the base end which extends the ram.  
 $Force = Pressure \times Surface Area.$
- Pressure within the hydraulic circuit causes P/O check valves (A) & (D) to open.

# RIGHT EXTEND – HYDRAULIC

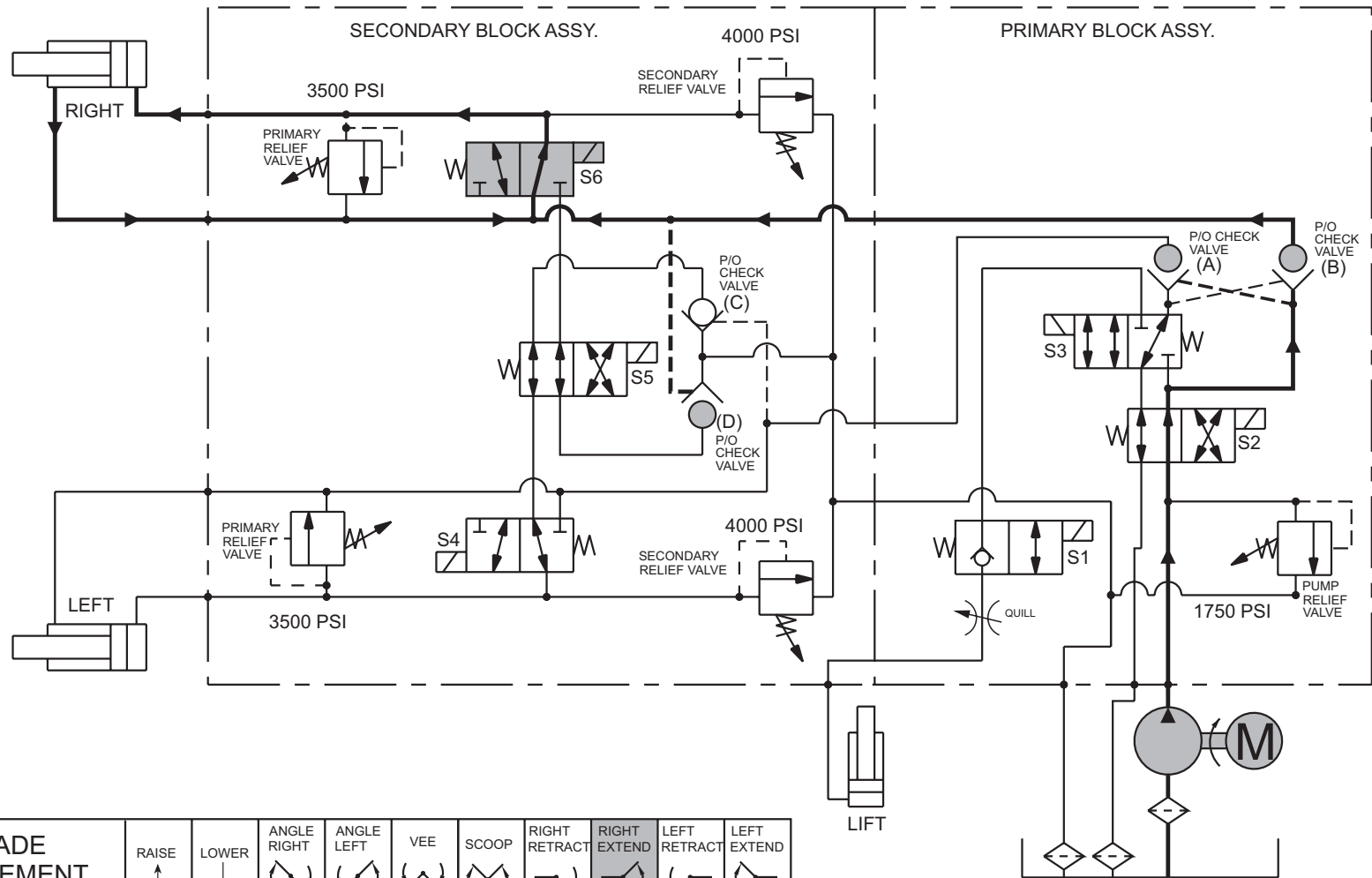

BLADE MOVEMENT		RAISE ↑	LOWER ↓	ANGLE RIGHT 	ANGLE LEFT 	VEE 	SCOOP 	RIGHT RETRACT 	RIGHT EXTEND 	LEFT RETRACT 	LEFT EXTEND 
MOTOR	M	ON		ON	ON	ON	ON	ON	ON	ON	ON
SV08-2004	S1		ON								
SV08-40	S2	ON			ON					ON	ON
SV08-43	S3	ON	ON			ON	ON				
SV08-30	S4						ON				ON
SV08-40	S5			ON	ON						
SV08-30	S6						ON		ON		

# LEFT RETRACT – ELECTRICAL

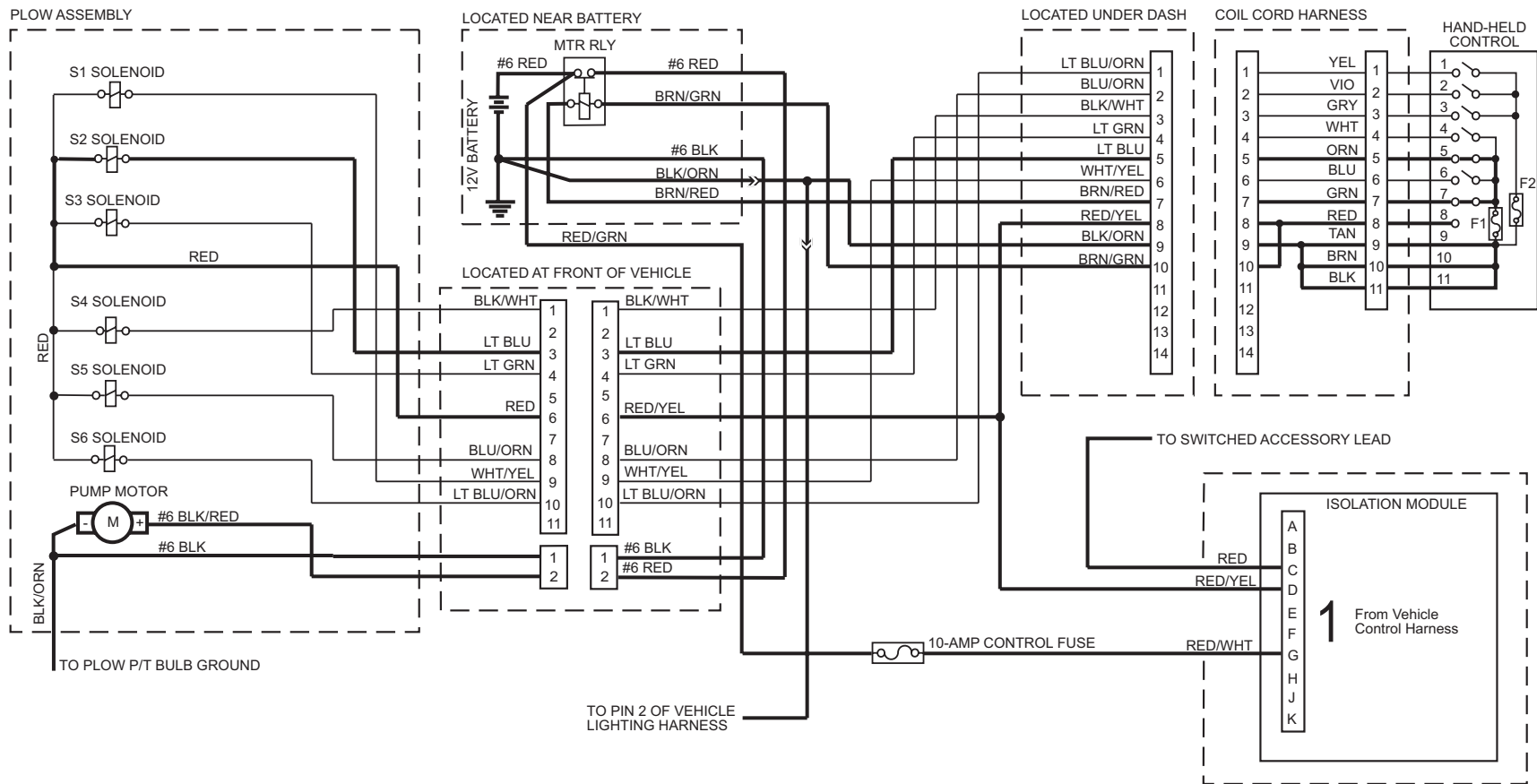

## System Response

1. By pressing the control button, the circuit board inside the cab control completes the ground path for the electrical circuit.
2. Electrical current flows through the motor relay, activating the pump motor, and solenoid cartridge valve S2, shifting its spool.
3. Hydraulic fluid from the pump flows through solenoid cartridge valves S2 & S3, P/O check valve (A), and into the rod end of the left ram causing it to retract.
4. Pressure within the hydraulic circuit causes P/O check valves (B) & (C) to open.
5. The retracting left ram pushes the hydraulic fluid out of its base end, through solenoid cartridge valves S4 & S5, through P/O check valve (C) and back to the reservoir.

# LEFT RETRACT – HYDRAULIC

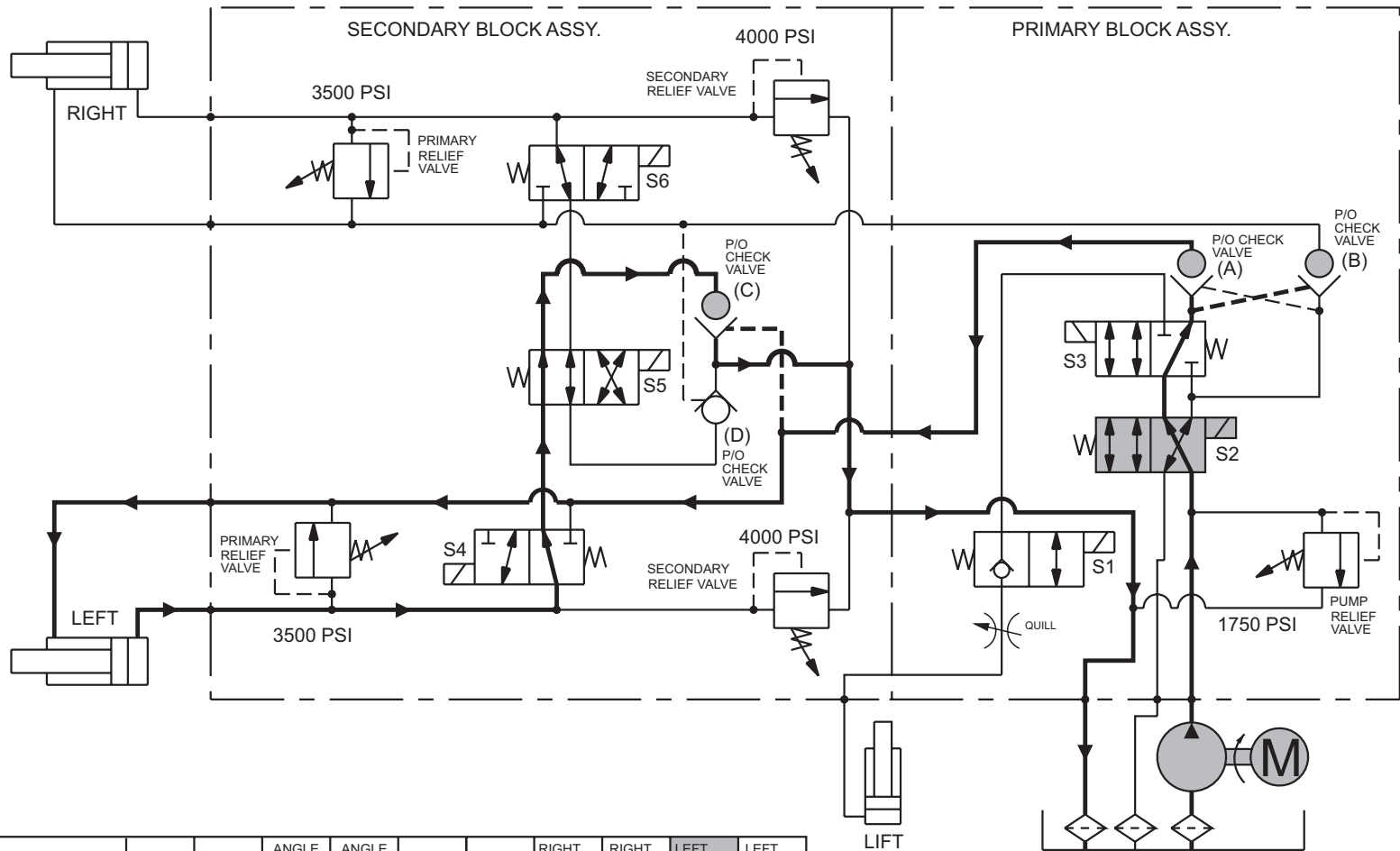

BLADE MOVEMENT		RAISE ↑	LOWER ↓	ANGLE RIGHT 	ANGLE LEFT 	VEE 	SCOOP 	RIGHT RETRACT 	RIGHT EXTEND 	LEFT RETRACT 	LEFT EXTEND 
MOTOR	M	ON		ON	ON	ON	ON	ON	ON	ON	ON
SV08-2004	S1		ON								
SV08-40	S2	ON			ON					ON	ON
SV08-43	S3	ON	ON			ON	ON				
SV08-30	S4						ON				ON
SV08-40	S5			ON	ON						
SV08-30	S6						ON	ON			

# LEFT EXTEND – ELECTRICAL

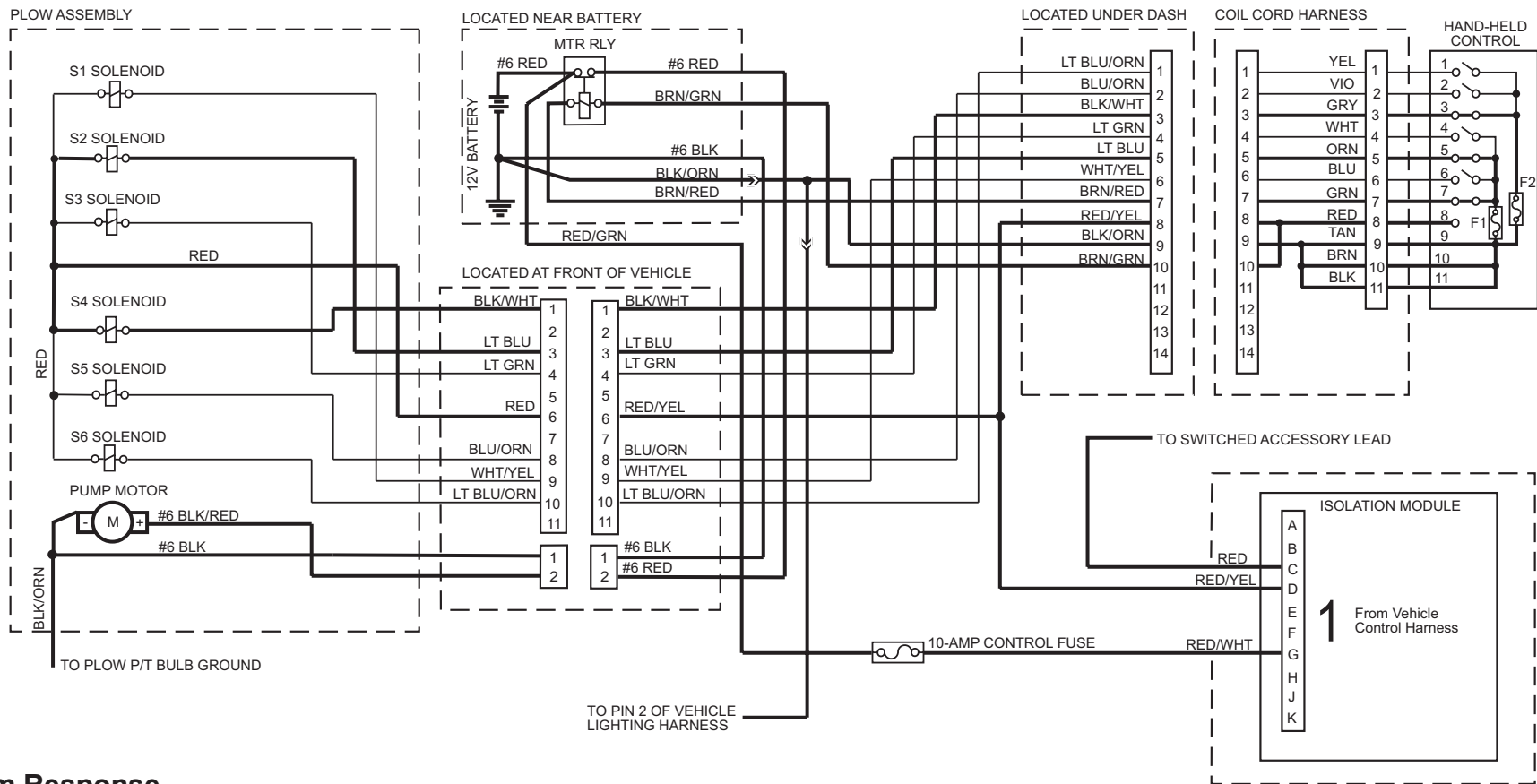







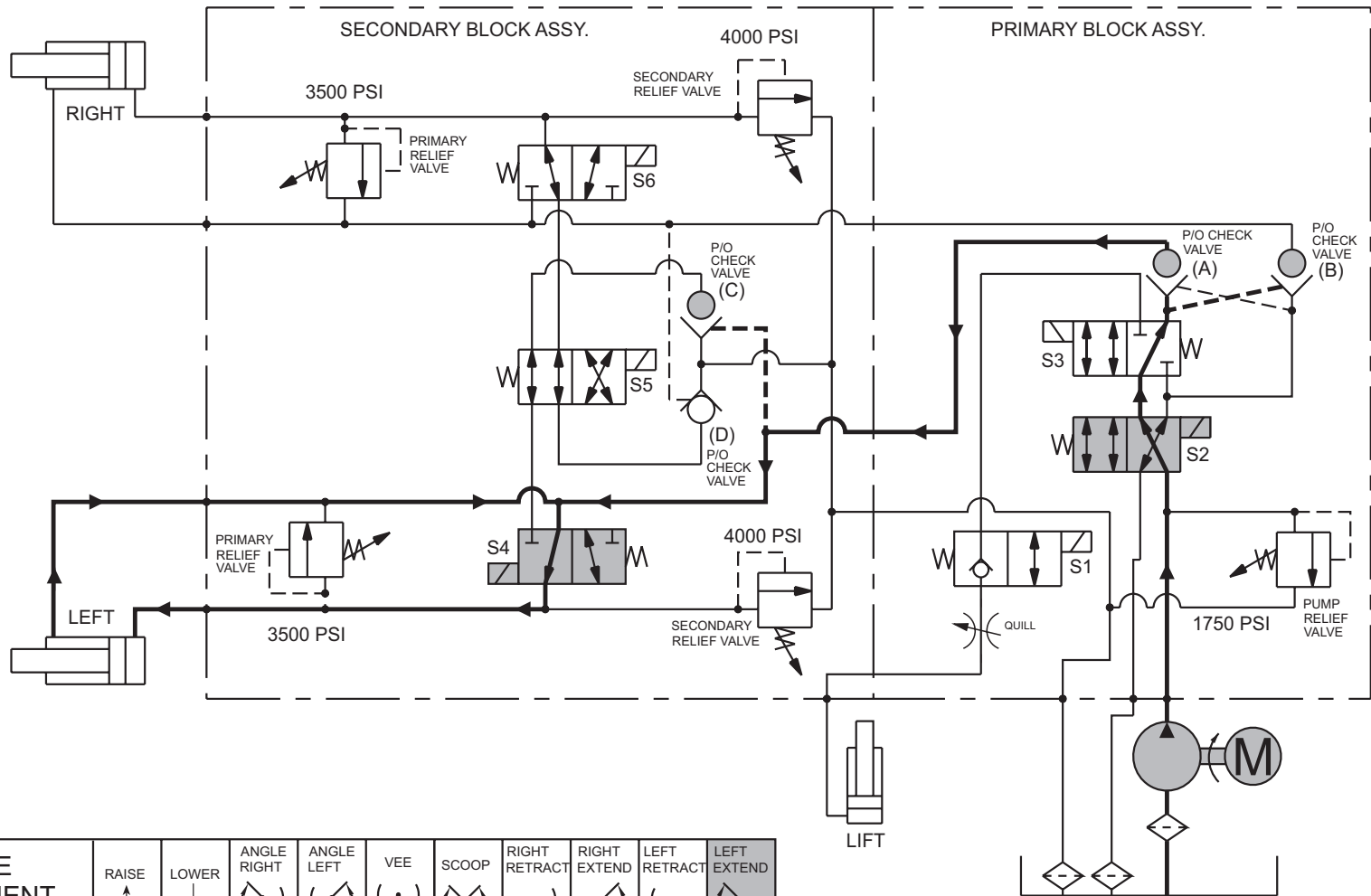

## System Response

- By pressing the control button, the circuit board inside the cab control completes the ground path for the electrical circuit.
  - Electrical current flows through the motor relay, activating the pump motor, and solenoid cartridge valves S2 & S4, shifting both spools.
  - Hydraulic fluid from the pump flows through solenoid cartridge valves S2 & S3, P/O check valve (A), solenoid cartridge valve S4 and into the base end of the left ram causing it to extend.
  - The extending left ram pushes the hydraulic fluid out of its rod end.
- This fluid mixes with the hydraulic fluid from the pump, passes through solenoid cartridge valve S4 and into the base end of the extending left ram. This is called a *regenerative hydraulic circuit*. Even though both sides of the ram piston will experience the same hydraulic pressure, the ram will extend due to unequal force. The difference in area between the base end and rod end of the ram piston creates a greater force on the base end which extends the ram.
- $$\text{Force} = \text{Pressure} \times \text{Surface Area.}$$
- Pressure within the hydraulic circuit causes P/O check valves (B) & (C) to open.



# LEFT EXTEND – HYDRAULIC



BLADE MOVEMENT		RAISE ↑	LOWER ↓	ANGLE RIGHT 	ANGLE LEFT 	VEE 	SCOOP 	RIGHT RETRACT 	RIGHT EXTEND 	LEFT RETRACT 	LEFT EXTEND 
MOTOR	M	ON		ON	ON	ON	ON	ON	ON	ON	ON
SV08-2004	S1		ON								
SV08-40	S2	ON			ON					ON	ON
SV08-43	S3	ON	ON			ON	ON				
SV08-30	S4						ON				ON
SV08-40	S5			ON	ON						
SV08-30	S6						ON	ON			

# HOLD IN RAISE POSITION – HYDRAULIC

## System Response

1. Hydraulic fluid is trapped in the base end of the lift ram by the internal check valve in solenoid cartridge valve S1.

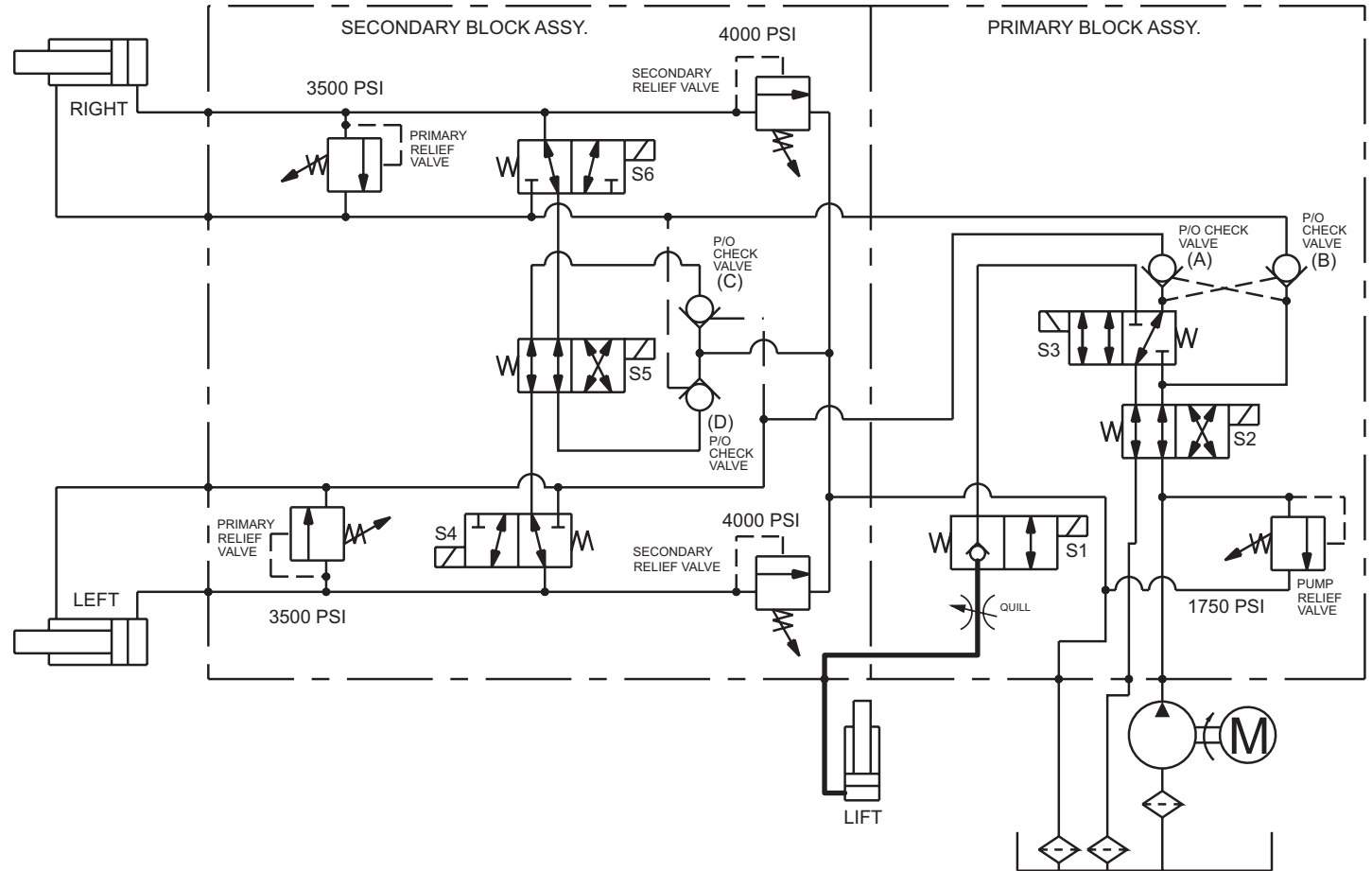

58

BLADE MOVEMENT		RAISE ↑	LOWER ↓	ANGLE RIGHT ↘	ANGLE LEFT ↙	VEE ∩	SCOOP ∪	RIGHT RETRACT ↖	RIGHT EXTEND ↗	LEFT RETRACT ↙	LEFT EXTEND ↘
MOTOR	M	ON		ON	ON	ON	ON	ON	ON	ON	ON
SV08-2004	S1		ON								
SV08-40	S2	ON			ON					ON	ON
SV08-43	S3	ON	ON			ON	ON				
SV08-30	S4						ON				ON
SV08-40	S5			ON	ON						
SV08-30	S6						ON	ON			

# STRIKING AN OBJECT WHILE PLOWING FORWARD – HYDRAULIC

## System Response

- Hydraulic fluid is trapped in the base end of the right ram by the right primary relief valve, right secondary relief valve, and P/O check valve (D). Hydraulic fluid is trapped in the base end of the left ram by left primary relief valve, left secondary relief valve, and P/O check valve (C).
- When the snowplow contacts an object on the front side of either wing, the force of the impact increases the hydraulic pressure in the base end of one ram. When the pressure exceeds 3500 psi, the ram's primary relief valve opens allowing some of the hydraulic fluid to move from the base end to rod end of the same ram.
- Due to the unequal displacement of fluid between the base and rod ends of the ram, hydraulic pressure continues to increase. When the pressure exceeds 4000 psi, the ram's secondary relief valve opens allowing the remaining hydraulic fluid back to the reservoir.

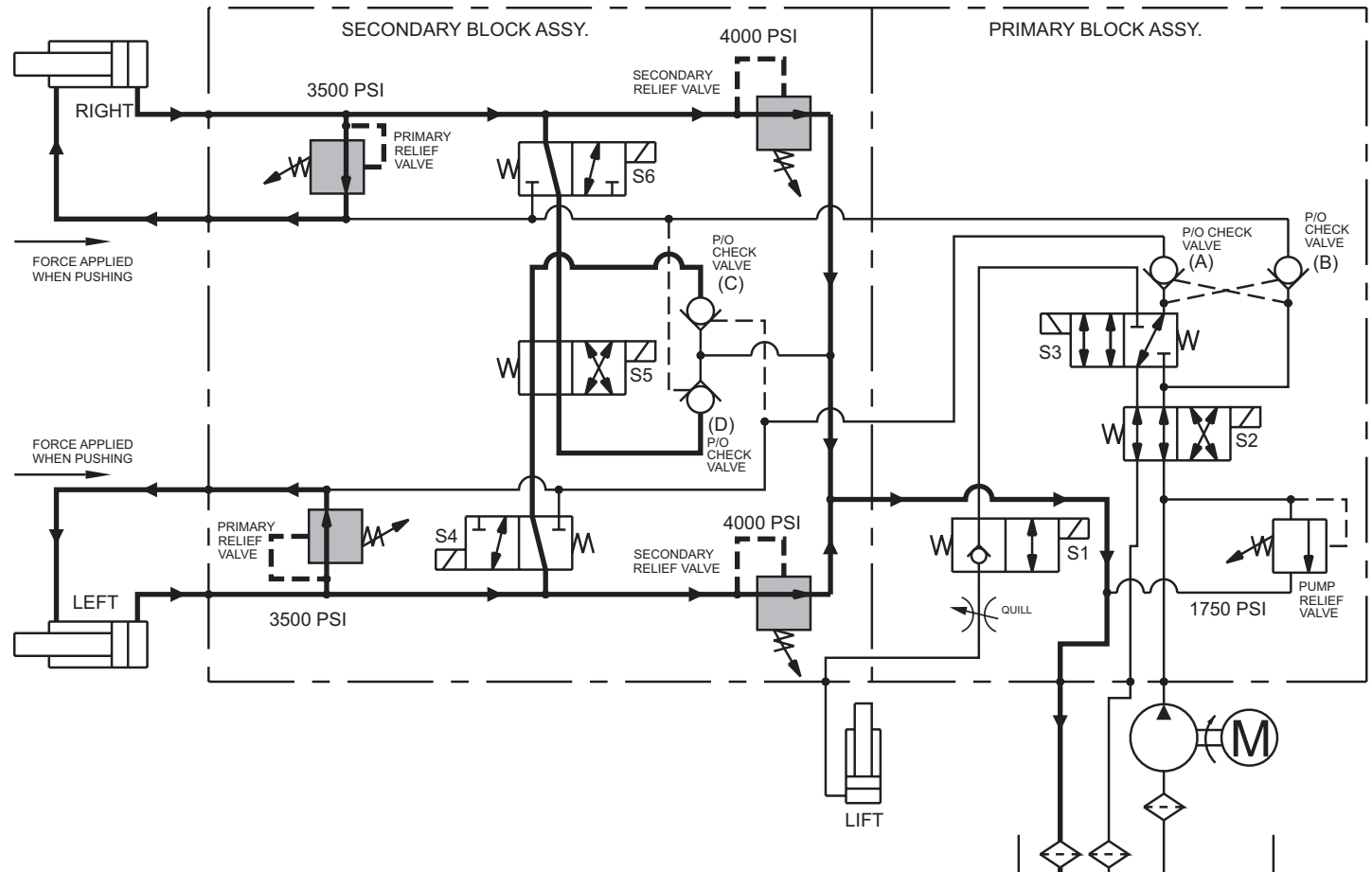

59

BLADE MOVEMENT		RAISE ↑	LOWER ↓	ANGLE RIGHT 	ANGLE LEFT 	VEE 	SCOOP 	RIGHT RETRACT 	RIGHT EXTEND 	LEFT RETRACT 	LEFT EXTEND 
MOTOR	M	ON		ON	ON	ON	ON	ON	ON	ON	ON
SV08-2004	S1		ON								
SV08-40	S2	ON			ON					ON	ON
SV08-43	S3	ON	ON			ON	ON				
SV08-30	S4						ON				ON
SV08-40	S5			ON	ON						
SV08-30	S6						ON	ON			

# STRIKING AN OBJECT WHILE BACK DRAGGING – HYDRAULIC

## System Response

- Hydraulic fluid is trapped in the rod end of the right ram by P/O check valve (B). Hydraulic fluid is trapped in the rod end of the left ram by P/O check valve (A). **The hydraulic system does not provide pressure relief while back dragging.**

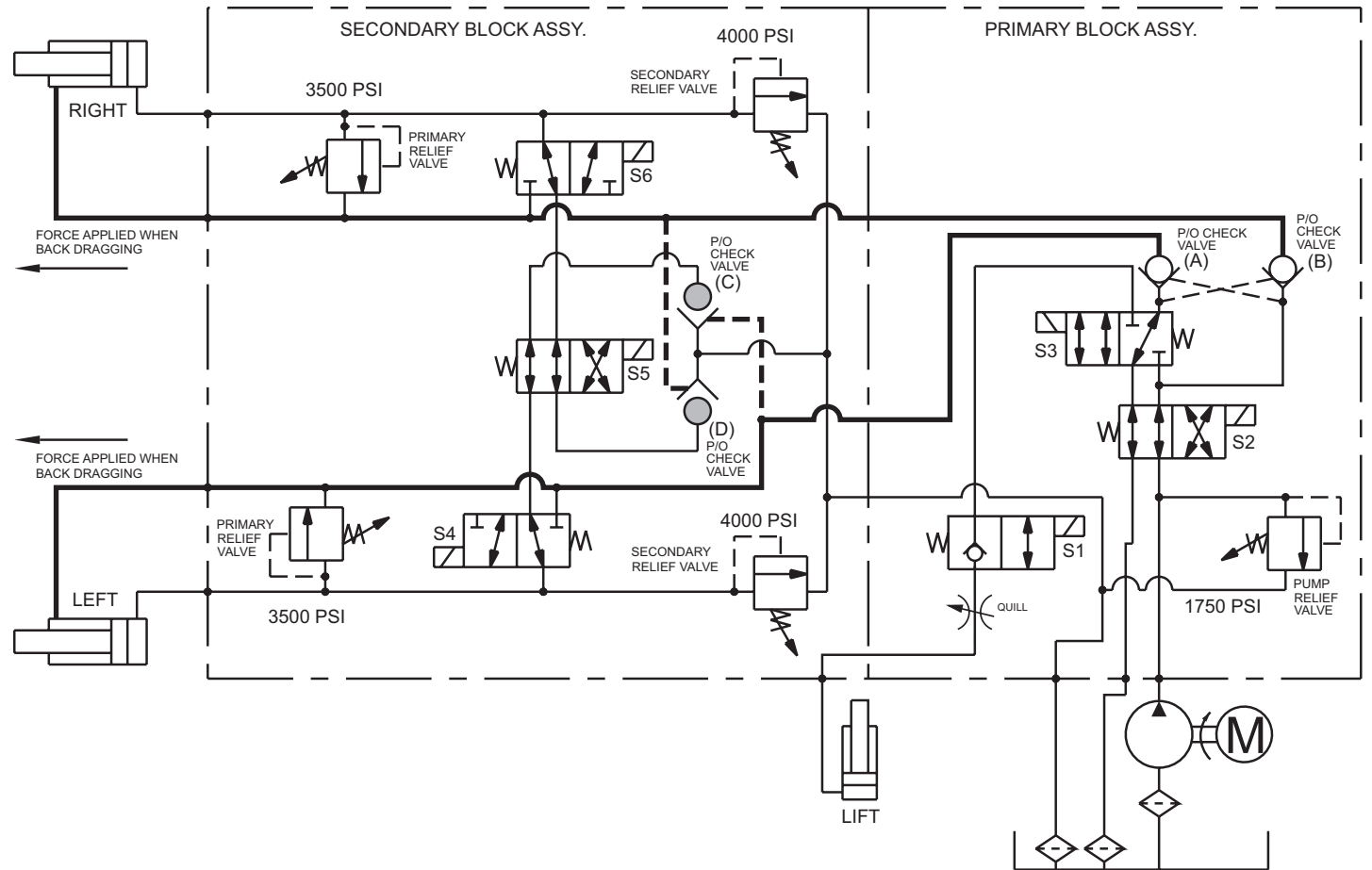

BLADE MOVEMENT		RAISE	LOWER	ANGLE RIGHT	ANGLE LEFT	VEE	SCOOP	RIGHT RETRACT	RIGHT EXTEND	LEFT RETRACT	LEFT EXTEND
		↑	↓	↘	↙	∩	∪	↖	↗	↙	↘
MOTOR	M	ON		ON	ON	ON	ON	ON	ON	ON	ON
SV08-2004	S1		ON								
SV08-40	S2	ON			ON					ON	ON
SV08-43	S3	ON	ON			ON	ON				
SV08-30	S4						ON				ON
SV08-40	S5			ON	ON						
SV08-30	S6						ON	ON			

# HIGH BEAM HEADLAMPS WITH SNOWPLOW CONNECTED TO VEHICLE (ISOLATION MODULE)

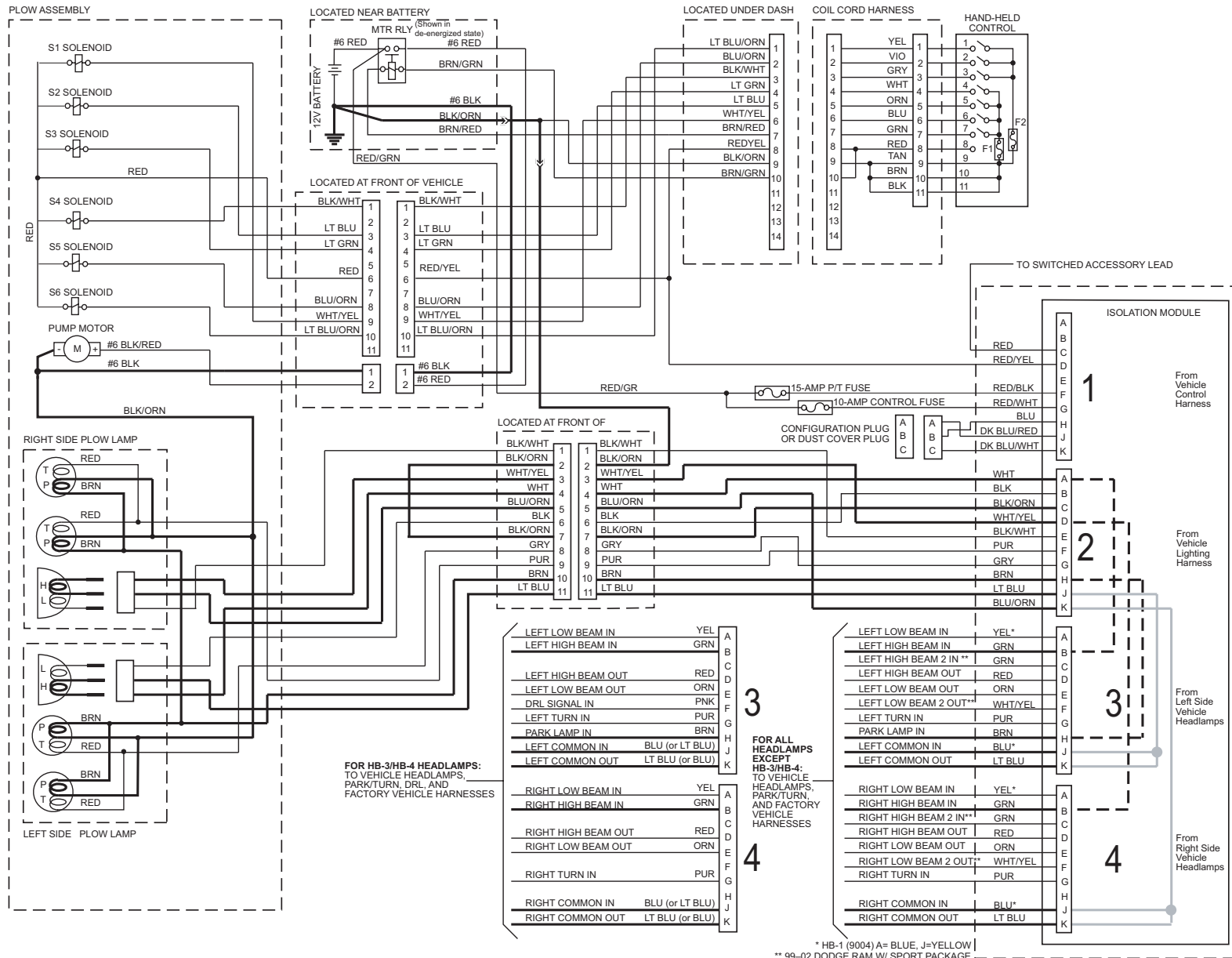

# LOW BEAM HEADLAMPS WITH SNOWPLOW CONNECTED TO VEHICLE (ISOLATION MODULE)

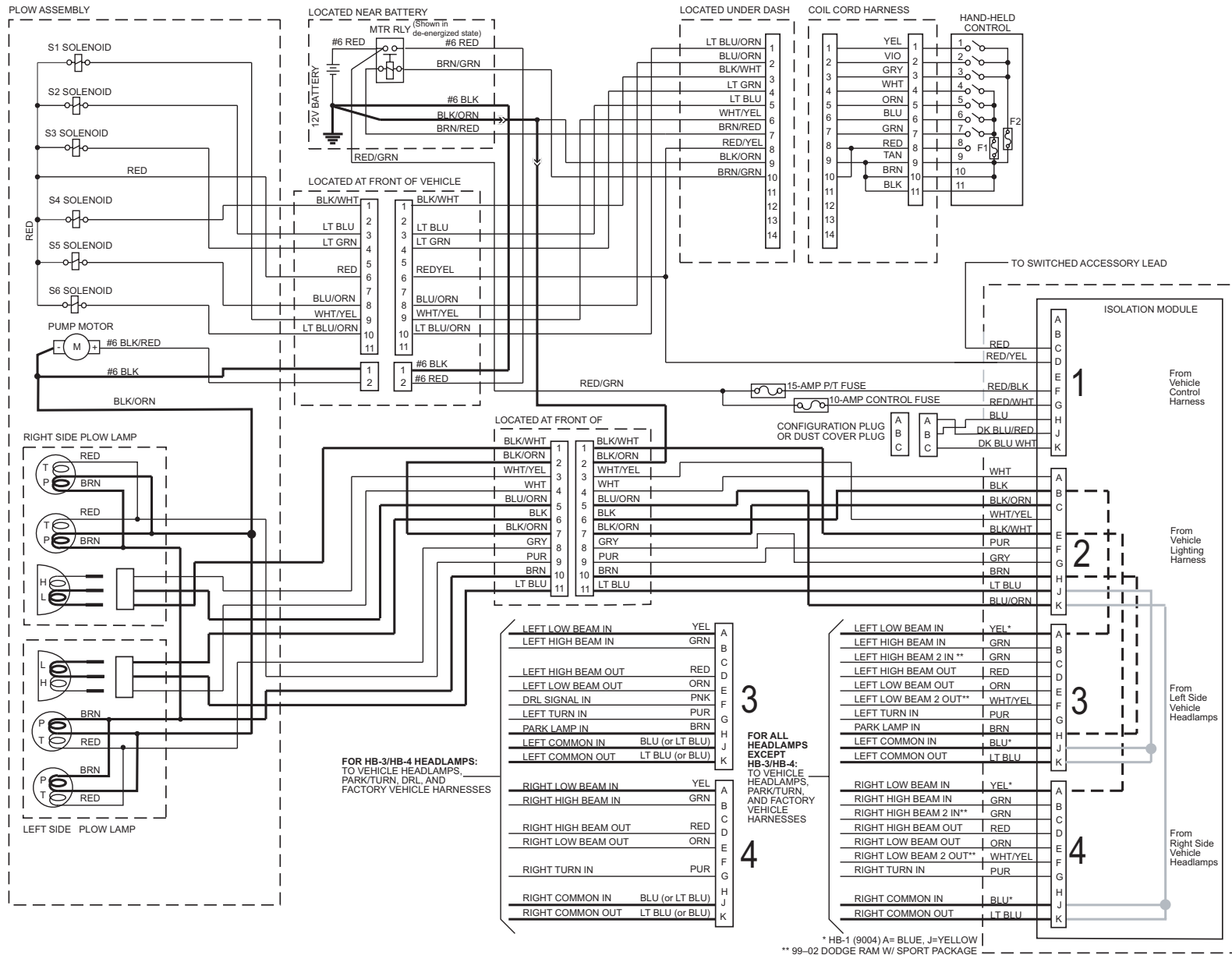

# TROUBLESHOOTING GUIDE – TABLE OF CONTENTS

---

Troubleshooting Guide .....	64	Configuration Plug Test .....	79
Introduction .....	64	Motor/Cable and Motor Relay Test Diagram .....	80
How to Use the Troubleshooting Guide .....	64	Motor/Cable Test .....	81
Electrical Testing .....	64	Motor Relay Test .....	82
Troubleshooting Tables .....	65	Vehicle Control Harness Test – Motor Relay .....	83
Headlamp Troubleshooting .....	66	Solenoid Coil Tests .....	84
Vehicle Headlamps .....	66	Solenoid Coil Activation Test .....	84
Snowplow Headlamps .....	67	Individual Solenoid Coil Test .....	84
Snowplow Park/Turn Lamps .....	68	Vehicle Control Harness Test – Solenoid Coils .....	85
Snowplow DRL Lamps .....	69	Control Test .....	86
General Diagnostic Table .....	70	Solenoid Cartridge Valve Inspection .....	87
Hydraulic System Test .....	73	Pump Pressure Test .....	88
Harness Tests .....	76	Relief Valve Inspection and Adjustment .....	89
Test Harness .....	76	Pilot-Operated In-Line Check Valve Inspection .....	90
Vehicle Control Harness (#1) .....	76		
Vehicle Lighting (#2) and Plug-In Harnesses (#3 & #4) .....	77		
w/White Isolation Module .....	77		
w/Green Isolation Module .....	78		

# TROUBLESHOOTING GUIDE

---

## INTRODUCTION

This guide contains a series of tables, diagrams, flowcharts, and other information. When used properly it helps the mechanic to identify and repair malfunctioning system components. Western Products highly recommends using the MVP® Electrical Tester as a timesaving tool for electrical system diagnosis. When using this tester, refer to the supplied instruction manual.

All malfunctions of the MVP snowplow can be categorized as mechanical, electrical or hydraulic. Mechanical issues are generally related to the blade wings, T-frame, lift frame and mount components and are usually identified by visual inspection. However, electrical and hydraulic issues can be difficult to trace to the component level, and that is the purpose of this troubleshooting guide.

**Read and understand the Theory of Operation before attempting troubleshooting.**

## HOW TO USE THE TROUBLESHOOTING GUIDE

Because of the relative complexity of the MVP snowplow electrical and hydraulic systems, some conditions must be eliminated in order to develop valid tests. These conditions are listed before the tables or flowcharts and must be satisfied before proceeding.

*If the listed conditions are not met, the procedure can result in inaccurate results and wasted time.*

In many cases, satisfying the listed conditions alone solves the problem.

1. Go to the beginning of the Troubleshooting Tables section (next page), and satisfy the ten listed conditions. These conditions **must** be met before proceeding into the table or to any subsequent test.
2. If having a lighting problem, proceed to the Headlamp Troubleshooting tables for a list of basic test questions and solutions to common problems.

3. If still having problems, go to the General Diagnostic table. Locate the condition in the table that best describes the problem and check possible causes and actions in the order listed.
4. Proceed to a service procedure, another condition, or a specific test as directed. Some tests use a flowchart format. To use the flowcharts, first satisfy any listed conditions at the top of the page. Then begin at the upper left square and proceed as directed.
5. Follow along sequentially through the tables and tests, referring to the Hydraulic & Electrical Schematics and System Overview sections as needed. Eventually the problem is identified at the component level.

## ELECTRICAL TESTING

Read and understand the section describing electrical circuit operation in the Theory of Operation section. A simple 12V test light with a ground lead can be used for circuit testing. When directed to check for 12 volts (12V), ground the test lamp lead and probe the terminal. When asked to check for ground, attach the test lamp lead to +12V and probe the terminal.

---

**NOTE: 12V is a nominal value. If using a voltmeter, actual voltage will vary with the vehicle and presence of loads in tested circuits. Continuity alone does not guarantee a good circuit. Poor connectors or damaged wires may have continuity but be unable to carry sufficient current.**

---



# TROUBLESHOOTING GUIDE

## TROUBLESHOOTING TABLES

Before using the following troubleshooting tables, or performing any tests, you must verify the following conditions:

1. Snowplow is attached to vehicle and all harnesses are connected.
2. Harness connector pins and terminals are free of corrosion, ensuring good connections, and coated with dielectric grease.
3. Vehicle battery and charging system are in good condition and battery connections are clean and tight.
4. Hydraulic reservoir is filled to proper level with recommended fluid when plow is in "vee" position and lift ram is fully retracted. See Product Specifications.
5. There are no fluid leaks from hoses, fittings, rams, or the hydraulic unit.
6. All built-up snow and ice is removed from the snowplow.
7. Vehicle control harness wires are correctly installed in the 14-pin connector, located in the cab.
8. 10-amp fuse in vehicle control harness is good.
9. Ignition is turned on or engine is running.
10. The control is connected in the cab and turned on.

**⚠ CAUTION**  
 Fill the reservoir to the fill level only. Do not overfill. Overfilling could damage the unit.

**⚠ CAUTION**  
 Do not mix different types of hydraulic fluid. Some fluids are not compatible and may cause performance problems and product damage.

---

**NOTE: Do not use a straight blade control with the adapter cable for these tests.**

---

### 14-Pin Connector Assignments

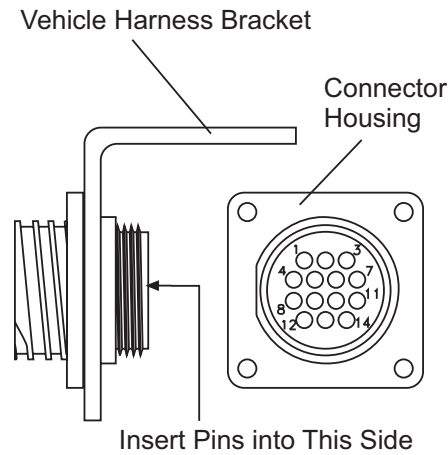

(Replacement terminal end [signal contacts]: PN 22123)

Wire Color	Pin
Light Blue w/ Orange Stripe	1
Blue w/ Orange Stripe	2
Black w/ White Stripe	3
Light Green	4
Light Blue	5
White w/ Yellow Stripe	6
Brown w/ Red Stripe	7
Red w/ Yellow Stripe	8
Black w/ Orange Stripe	9
Brown w/ Green Stripe	10

# TROUBLESHOOTING GUIDE

## HEADLAMP TROUBLESHOOTING – VEHICLE HEADLAMPS

### Incorrect Operation or No Headlamps

	BASIC CHECK QUESTIONS	SOLUTIONS
1	Correct Isolation Module kit installed for application	Verify per Quick Match at <a href="http://www.westernplows.com">www.westernplows.com</a> .
2	OEM lights operating correctly prior to installation	OEM headlamps must be fully operational for correct Isolation Module operation.
3	OEM fuse tests good	Replace with proper fuse.
4	OEM headlamp bulb operational	Replace with proper bulb.
5	Plugged into OEM headlamp correctly	Connect per Isolation Module instructions.
6	Harnesses in correct location at Isolation Module and installed per installation instructions	Install using Isolation Module instructions.
7	Harnesses #3 & #4 configured correctly for HB-1/HB-5 and/or kits using adaptors	Install using Isolation Module instructions or Electrical Schematics Guide.
8	Configuration plug correct (if required)	Refer to Isolation Module instructions or Electrical Schematics Guide, or go to <b>Configuration Plug Test</b> .
9	Correct harnesses and/or Isolation Module in kit	Refer to Electrical Schematics Guide.
10	Harness wired per drawing	Refer to Electrical Schematics Guide.
11	DRL mode/automatic headlamp function	Fully understand OEM headlamp operation; refer to vehicle owner's manual.
12	Test Isolation Module with Isolation Module tester	Test using instructions supplied with tester.
13	Verify power and ground in proper pin locations at Isolation Module	See wiring diagram in this guide and go to <b>Harness Tests</b> .
14	Verify power and ground in proper pin locations to vehicle headlamp	See wiring diagram in this guide and go to <b>Harness Tests</b> .

# TROUBLESHOOTING GUIDE

## HEADLAMP TROUBLESHOOTING – SNOWPLOW HEADLAMPS

### Incorrect Operation or No Headlamps

	BASIC CHECK QUESTIONS	SOLUTIONS
1	Harnesses connected at vehicle and snowplow (all)	Harnesses must be connected for all snowplow and headlamp functions.
2	Corrosion at harness connectors	Replace as needed.
3	Ignition on	Ignition must be "on" for snowplow headlamps to operate.
4	Control powers up with key on	Go to <b>Control Test</b> .
5	Correct Isolation Module kit installed for application	Verify per Quick Match at <a href="http://www.westernplows.com">www.westernplows.com</a> .
6	OEM lights operating correctly prior to installation	OEM headlamps must be fully operational for correct Isolation Module operation.
7	OEM fuse tests good	Replace with proper fuse.
8	Bulb burned out	Replace with proper bulb.
9	Plugged into OEM headlamp correctly	Connect per Isolation Module instructions.
10	Harnesses in correct location at Isolation Module and installed per installation instructions	Install using Isolation Module instructions.
11	Harnesses #3 & #4 configured correctly for HB-1/HB-5 and/or kits using adaptors	Install using Isolation Module instructions or Electrical Schematics Guide.
12	Configuration plug correct (if required)	Refer to Isolation Module instructions or Electrical Schematics Guide, or go to <b>Configuration Plug Test</b> .
13	Correct harnesses and/or Isolation Module in kit	Refer to Electrical Schematics Guide.
14	Harness wired per drawing	Refer to Electrical Schematics Guide.
15	DRL mode/automatic headlamp function	Fully understand OEM headlamp operation; refer to vehicle owner's manual.
16	Test Isolation Module with Isolation Module tester	Test using instructions supplied with tester.
17	Verify power and ground in proper pin locations at Isolation Module	See wiring diagram in this guide and go to <b>Harness Tests</b> .
18	Verify power and ground in proper pin locations to vehicle headlamp	See wiring diagram in this guide and go to <b>Harness Tests</b> .

# TROUBLESHOOTING GUIDE

## HEADLAMP TROUBLESHOOTING – SNOWPLOW PARK/TURN LAMPS\*

### Incorrect Operation or No Park/Turn Lamps

	BASIC CHECK QUESTIONS	SOLUTIONS
1	OEM park/turn lamps working	Refer to vehicle owner's manual for fuse location and size.
2	Harnesses connected at vehicle and snowplow (all)	Harnesses must be connected for all snowplow and headlamp functions.
3	Corrosion at harness connectors	Replace as needed.
4	Ignition on	Ignition must be "on" for snowplow headlamps to operate.
5	Control powers up with key on	Go to <b>Control Test</b> .
6	15-amp park/turn fuse good in #1 harness	Replace with proper fuse.
7	Black/orange "ground" wire connected to motor ground stud	Refer to Isolation Module instructions or Electrical Schematics Guide.
8	Spliced into OEM park/turn circuit correctly	Refer to Isolation Module instructions.
9	Harnesses in correct location at Isolation Module and installed per installation instructions	Install using Isolation Module instructions.
10	Harness wired per drawing	Refer to Electrical Schematics Guide.
11	Verify power and ground in proper pin locations at Isolation Module	See wiring diagram in this guide and go to <b>Harness Tests</b> .
12	Verify power and ground in proper pin locations to vehicle headlamp	See wiring diagram in this guide and go to <b>Harness Tests</b> .
13	Bulb burned out	Replace with proper bulb.

\* Some applications may use the turn circuit for DRLs.

# TROUBLESHOOTING GUIDE

---

## HEADLAMP TROUBLESHOOTING – SNOWPLOW DRL LAMPS\*

### Incorrect Operation or No DRL Lamps

	<b>BASIC CHECK QUESTIONS</b>	<b>SOLUTIONS</b>
1	Fully understand OEM DRL operation	Refer to vehicle owner's manual for DRL operation.
2	OEM headlamps and DRLs operating correctly	OEM headlamps must be fully operational for correct Isolation Module operation.
3	OEM DRL fuse tests good	Refer to vehicle owner's manual for fuse location and size.
4	Harnesses connected at vehicle and snowplow (all)	Harnesses must be connected for all snowplow and headlamp functions.
5	Corrosion at harness connectors	Replace as needed.
6	Ignition on	Ignition must be "on" for snowplow DRL operation.
7	Does control power up with key on	Go to <b>Control Test</b> .
8	Snowplow headlamp and park/turn lamps all working correctly	See wiring diagram in this guide and go to <b>Harness Tests</b> .
9	Correct Isolation Module kit installed for application	Verify per Quick Match at <a href="http://www.westernplows.com">www.westernplows.com</a> .
10	Isolation Module and harnesses correctly installed per instructions	Refer to Isolation Module instructions.
11	Harness wired per drawing	Refer to Electrical Schematics Guide.
12	Bulb burned out	Replace with proper bulb.

\* Snowplow DRLs operate as a series circuit and will illuminate bulb at 1/2 intensity. In some applications, the OEM DRLs will stay illuminated with snowplow attached.

# TROUBLESHOOTING GUIDE

## GENERAL DIAGNOSTIC TABLE

CONDITION	POSSIBLE CAUSE	ACTION
Motor does not run for any requested function.	Poor connections in vehicle or snowplow battery cables.	Clean and reestablish connections.
	Motor worn or damaged or pump seized.	Go to <b>Motor Test</b> .
	Motor relay inoperative.	Go to <b>Motor Relay Test</b> .
	Fault in vehicle control wiring harness.	Go to <b>Vehicle Control Harness Test</b> .
	Malfunctioning control.	Go to <b>Control Test</b> .
Motor runs continuously.	Motor relay sticking or always energized.	Go to <b>Motor Relay Test</b> .
	Fault in vehicle control harness wiring.	Go to <b>Vehicle Control Harness Test</b> .
	Malfunctioning control.	Go to <b>Control Test</b> .
Snowplow won't raise — motor runs.	Clogged pump filter (all functions are affected). *	Clean or replace filter, flush reservoir.
	Worn or damaged pump.	Go to <b>Pump Pressure Test</b> .
	Solenoid valve coils not energizing properly.	Go to <b>Solenoid Coil Activation Test</b> .
	Hydraulic system malfunction. *	Go to <b>Hydraulic System Test</b> .
	Malfunctioning control.	Go to <b>Control Test</b> .
Snowplow raises slowly or partially — motor runs.	Quill adjusted in too far.	Adjust quill out.
	Clogged pump filter (all functions are affected). *	Clean or replace filter, flush reservoir.
	Worn or damaged pump.	Go to <b>Pump Pressure Test</b> .
	Malfunctioning control.	Go to <b>Control Test</b> .
In <i>straight blade</i> mode, snowplow angles slowly or partially -or- In <i>wing</i> mode, wings move slowly or partially — motor runs.	Air in angle rams.	Check fluid level. Cycle wings stop to stop to remove air.
	Relief valves damaged or out of adjustment.	Go to <b>Relief Valve Inspection and Adjustment</b> .
	Clogged pump filter (all functions are affected). *	Clean or replace filter, flush reservoir.
	Worn or damaged pump.	Go to <b>Pump Pressure Test</b> .
	Solenoid valve coils not activating properly.	Go to <b>Solenoid Coil Activation Test</b> .
	Hydraulic system malfunction. *	Go to <b>Hydraulic System Test</b> .
	Angle rams damaged or bypassing internally.	Rebuild or replace angle ram.
Snowplow will not lower or lowers slowly, or won't float.	Quill adjusted in too far.	Adjust quill out.
	Solenoid valve coils not activating properly.	Go to <b>Solenoid Coil Activation Test</b> .
	Hydraulic system malfunction. *	Go to <b>Hydraulic System Test</b> .

\* Thread sealant/tape is not compatible with hydraulics.

# TROUBLESHOOTING GUIDE

## GENERAL DIAGNOSTIC TABLE

CONDITION	POSSIBLE CAUSE	ACTION
Snowplow lowers by itself or won't stay in raised position	Solenoid valve coils not activating properly.	Go to <b>Solenoid Coil Activation Test</b> .
	Hydraulic system malfunction. *	Go to <b>Hydraulic System Test</b> .
	Malfunctioning control.	Go to <b>Control Test</b> .
Wings will not lock hydraulically or hold position.	Air in angle rams.	Cycle wings stop to stop to remove air.
	Relief valves damaged or out of adjustment.	Go to <b>Relief Valve Inspection &amp; Adjustment</b> .
	P/O check valve stuck open.	Go to <b>P/O Check Valve Inspection</b> .
	Solenoid coils not activating properly.	Go to <b>Solenoid Coil Activation Test</b> .
	Hydraulic system malfunction. *	Go to <b>Hydraulic System Test</b> .
	Angle rams damaged or leaking internally.	Repair or replace angle rams.
Snowplow does not perform the selected function or performs a different function.	Hydraulic hose routing incorrect.	Verify correct hose installation. See Hydraulic Hose Routing diagram.
	Solenoid valve coils not energizing properly.	Go to <b>Solenoid Coil Activation Test</b> .
	Hydraulic system malfunction. *	Go to <b>Hydraulic System Test</b> .
	Malfunctioning control.	Go to <b>Control Test</b> .
Control times out prior to completing function. **	Oil reservoir not filled to proper level.	Fill hydraulic unit per instructions in Owner's Manual.
	Clogged pump filter (all functions are affected). *	Clean or replace filter, flush reservoir.
	Water contamination in hydraulic fluid.	Drain and change hydraulic fluid.
	Motor operating incorrectly.	Go to <b>Motor/Cable Test</b> .
	Electrical charging system malfunction.	See OEM for assistance.
	Battery not fully charged.	See OEM for assistance.
	Hydraulic system malfunction. *	Go to <b>Hydraulic System Test</b> .
Vehicle control harness 10-amp fuse blows.	Red wire in snowplow control harness going to solenoid valve coils is shorted to ground.	Repair wire or replace snowplow control harness.
	Red/yellow wire in vehicle control harness is shorted to ground.	Repair wire or replace harness.
	Brown/green wire in vehicle control harness going to motor relay primary is shorted to ground.	Repair wire or replace harness.
	Malfunctioning control.	Go to <b>Control Test</b> .

\* Thread sealant/tape is not compatible with hydraulics.

\*\* First verify control function time outs by going to **System Overview – Controls**.

## TROUBLESHOOTING GUIDE

---

### GENERAL DIAGNOSTIC TABLE

CONDITION	POSSIBLE CAUSE	ACTION
Control F1 fuse blows.	Motor relay primary shorted internally.	Replace motor relay.
	Solenoid valve coil S1, S2 or S3 shorted internally.	Go to <b>Individual Solenoid Coil Test</b> .
Control F2 fuse blows.	Solenoid valve coil S4, S5 or S6 shorted internally.	Go to <b>Individual Solenoid Coil Test</b> .
Vehicle accessory fuse blows.	Circuit overloaded.	Consult vehicle owner's manual for correct application of aftermarket electrical loads.
Excessive load on vehicle electrical system while using snowplow.	Quill adjusted in too far.	Adjust quill out.
	Pump pressure set too high.	Go to <b>Pump Pressure Test</b> .
	Worn or damaged motor or pump.	Go to <b>Pump Pressure Test</b> .
	Poor connections on battery cables.	Inspect battery cables, clean and reattach all connections.



# TROUBLESHOOTING GUIDE

## HYDRAULIC SYSTEM TEST

This test consists of trying all ten snowplow functions and comparing the snowplow reaction to the action requested in the following table. The table will pinpoint malfunctioning solenoid valves or closed P/O check valves accurately if **only one** component is malfunctioning. If the snowplow reaction for a given function is not listed in the table, there may be relief or P/O check valves that are stuck open or contaminated; there may be missing

or damaged O-rings or backing rings on solenoid, relief or P/O check valves; or there may be two or more malfunctioning components. In this case, use the specific function hydraulic schematic and carefully inspect each component in the flow circuit. If contamination is evident in more than one component, the hydraulic unit, hoses and rams must be completely disassembled, inspected and cleaned.

1. Perform Solenoid Coil Activation Test first.
2. Verify hydraulic hose installation is correct. Refer to the Hose Routing diagram.
3. Test all of the snowplow functions.
4. Inspect and clean or replace the suspected component. Refer to the System Overview – Hydraulic Section.
5. Refer to the sections following the table for inspection and adjustment of solenoid, cartridge valves, P/O check valves and relief valves.

---

**IMPORTANT: When testing the snowplow functions, be sure the control is not in "float."**

---

ACTION REQUESTED	PLOW REACTION	POSSIBLE CAUSE
Raise	Vee	S2 not shifted
	Left Retract	S3 not shifted
	Raises very slowly	S1 stuck shifted
Hold Raised	Lower	S1 stuck shifted or has malfunctioning internal check valve
Lower	Lowers very slowly	S2 stuck shifted
	None	S3 not shifted S1 not shifted
Angle Right	Angle Left	S2 stuck shifted
	None	S3 stuck shifted Check valve B closed Check valve A closed
	Right Extend	S6 stuck shifted
	Right Retract	S5 not shifted
	None	S4 stuck shifted

# TROUBLESHOOTING GUIDE

## HYDRAULIC SYSTEM TEST

ACTION REQUESTED	PLOW REACTION	POSSIBLE CAUSE
Angle Left	Angle Right	S2 not shifted
	Raise	S3 stuck shifted
	None	Check valve A closed Check valve B closed
	Left Extend	S4 stuck shifted
	Left Retract	S5 not shifted
	None	S6 stuck shifted
Vee	Raise	S2 stuck shifted
	Right Retract	S3 not shifted Check valve A closed Check valve C closed
	Left Retract	Check valve B closed
	Left Extend and Right Retract—wings not locked	S4 stuck shifted
	Left Retract	Check valve D closed
	None	S5 stuck shifted
	Left Retract and Right Extend—wings not locked	S6 stuck shifted
Scoop	Raise	S2 stuck shifted
	Right Extend—left wing floats	S3 not shifted
	Right Extend	Check valve A closed
	Left Extend	Check valve B closed
	Right Extend and Left Retract—wings not locked	S4 not shifted
	Left Extend	S6 not shifted

# TROUBLESHOOTING GUIDE

## HYDRAULIC SYSTEM TEST

ACTION REQUESTED	PLOW REACTION	POSSIBLE CAUSE
Right Retract	Left Retract	S2 stuck shifted
	Vee	S3 stuck shifted
	None	Check valve B closed Check valve D closed
	Right Extend	S6 stuck shifted
	Angle Right	S5 stuck shifted
Right Extend	Left Retract	S2 stuck shifted
	Right Extend and Left Retract—wings not locked	S3 stuck shifted
	None	Check valve B closed
	Right Retract	S6 not shifted
Left Retract	Right Retract	S2 not shifted
	Raise	S3 stuck shifted
	None	Check valve A closed Check valve C closed
	Left Extend	S4 stuck shifted
	Angle Left	S5 stuck shifted
Left Extend	Right Retract	S2 not shifted
	Raise	S3 stuck shifted
	None	Check valve A closed
	Left Retract	S4 not shifted

# HARNESSES TESTS

## TEST HARNESS (PN 28957)

Connecting this harness between any of the four Isolation Module harnesses and the module will allow you to test each circuit "live" by checking for voltage or ground at specified locations as described in this guide.

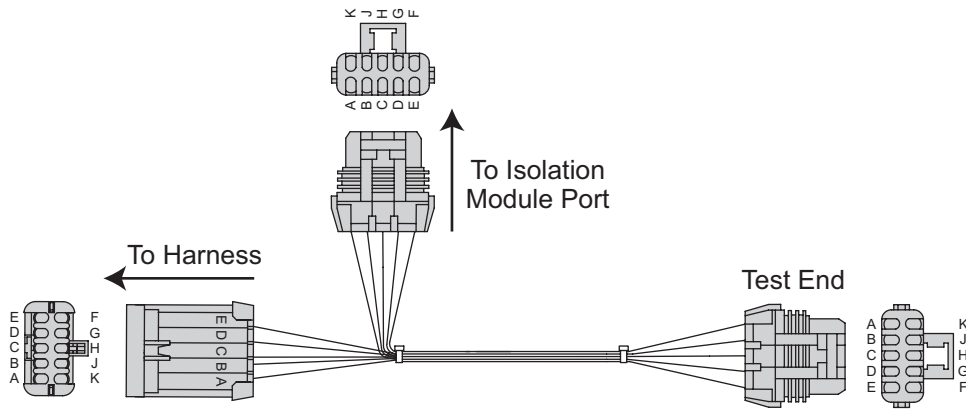

## VEHICLE CONTROL HARNESS (#1)

10-Pin Connector	Ignition on & snowplow connected	Ignition on & snowplow disconnected
<b>A</b>	Unused	Unused
<b>B</b>	Unused	Unused
<b>C</b>	12V from ignition	12V from ignition
<b>D</b>	<b>12V to control/coils</b>	<b>No power</b>
<b>E</b>	Unused	Unused
<b>F</b>	12V from 15-amp fuse holder	12V from 15-amp fuse holder
<b>G</b>	12V from 10-amp fuse holder	12V from 10-amp fuse holder
<b>H</b>	Common to Isolation Module	Common to Isolation Module
<b>J</b>	Ground from Isolation Module	Ground from Isolation Module
<b>K</b>	12V from Isolation Module	12V from Isolation Module

## HARNESSES TESTS

### VEHICLE LIGHTING (#2) AND PLUG-IN HARNESSES (#3 & #4) w/WHITE ISOLATION MODULE

#### Common (-) System

Function	Test Location									
	Harness #3		Harness #4		Harness #3		Harness #4		Harness #2	
	input to module		input to module		output to vehicle		output to vehicle		output to plow	
	12V	neg	12V	neg	12V	neg	12V	neg	12V	neg
Left Low Beam	A	K	-	-	E	J	-	-	B	J
Left High Beam	B	K	-	-	D	J	-	-	A	J
Left High Beam #2	N/A		N/A		N/A		N/A		N/A	
Right Low Beam	-	-	A	K	-	-	E	J	E	K
Right High Beam	-	-	B	K	-	-	D	J	D	K
Right High Beam #2	N/A		N/A		N/A		N/A		N/A	
Left Turn Signal Lamp	G	-	-	-	-	-	-	-	G	*
Right Turn Signal Lamp	-	-	G	-	-	-	-	-	F	*
Park Lamp	H	-	-	-	-	-	-	-	H	*

77

#### Common (+) System

Function	Test Location									
	Harness #3		Harness #4		Harness #3		Harness #4		Harness #2	
	input to module		input to module		output to vehicle		output to vehicle		output to plow	
	12V	neg	12V	neg	12V	neg	12V	neg	12V	neg
Left Low Beam	K	A	-	-	J	E	-	-	J	B
Left High Beam	K	B	-	-	J	D	-	-	J	A
Left High Beam #2	K	C	-	-	J	F	-	-	-	-
Right Low Beam	-	-	K	A	-	-	J	E	K	E
Right High Beam	-	-	K	B	-	-	J	D	K	D
Right High Beam #2	-	-	K	C	-	-	J	F	-	-
Left Turn Signal Lamp	G	-	-	-	-	-	-	-	G	*
Right Turn Signal Lamp	-	-	G	-	-	-	-	-	F	*
Park Lamp	H	-	-	-	-	-	-	-	H	*

\* Ground is completed by the black/orange wire at the motor NEGATIVE (-) post.

# HARNESSES TESTS

## VEHICLE LIGHTING (#2) AND PLUG-IN HARNESSES (#3 & #4) w/GREEN ISOLATION MODULE

### Common (-) System

Function	Test Location									
	Harness #3		Harness #4		Harness #3		Harness #4		Harness #2	
	input to module		input to module		output to vehicle		output to vehicle		output to plow	
	12V	neg	12V	neg	12V	neg	12V	neg	12V	neg
Left Low Beam	A	K	-	-	E	J	-	-	B	J
Left High Beam	B	K	-	-	D	J	-	-	A	J
Right Low Beam	-	-	A	K	-	-	E	J	E	K
Right High Beam	-	-	B	K	-	-	D	J	D	K
DRL Lamp**	F								K	J
Left Turn Signal Lamp	G	-	-	-	-	-	-	-	G	*
Right Turn Signal Lamp	-	-	G	-	-	-	-	-	F	*
Park Lamp	H	-	-	-	-	-	-	-	H	*

78

### Common (+) System

Function	Test Location									
	Harness #3		Harness #4		Harness #3		Harness #4		Harness #2	
	input to module		input to module		output to vehicle		output to vehicle		output to plow	
	12V	neg	12V	neg	12V	neg	12V	neg	12V	neg
Left Low Beam	K	A	-	-	J	E	-	-	J	B
Left High Beam	K	B	-	-	J	D	-	-	J	A
Right Low Beam	-	-	K	A	-	-	J	E	K	E
Right High Beam	-	-	K	B	-	-	J	D	K	D
DRL Lamp**	F	-	-	-	-	-	-	-	K	J
Left Turn Signal Lamp	G	-	-	-	-	-	-	-	G	*
Right Turn Signal Lamp	-	-	G	-	-	-	-	-	F	*
Park Lamp	H	-	-	-	-	-	-	-	H	*

\* Ground is completed by the black/orange wire at the motor NEGATIVE (-) post.

\*\* DRL Systems using the Pink wire run a snowplow low beam series circuit.

# CONFIGURATION PLUG TEST

## 1. Remove configuration plug.

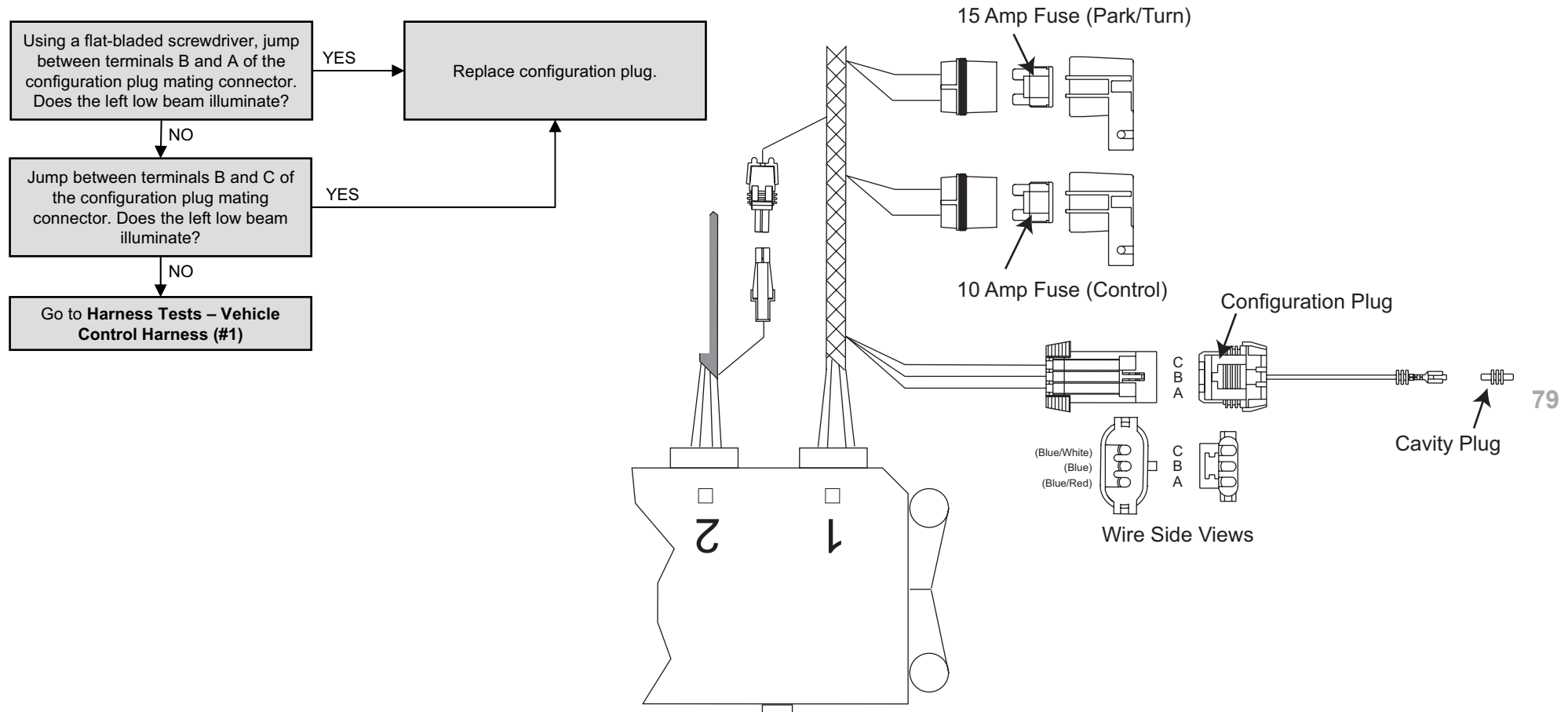

# MOTOR/CABLE AND MOTOR RELAY TEST DIAGRAM

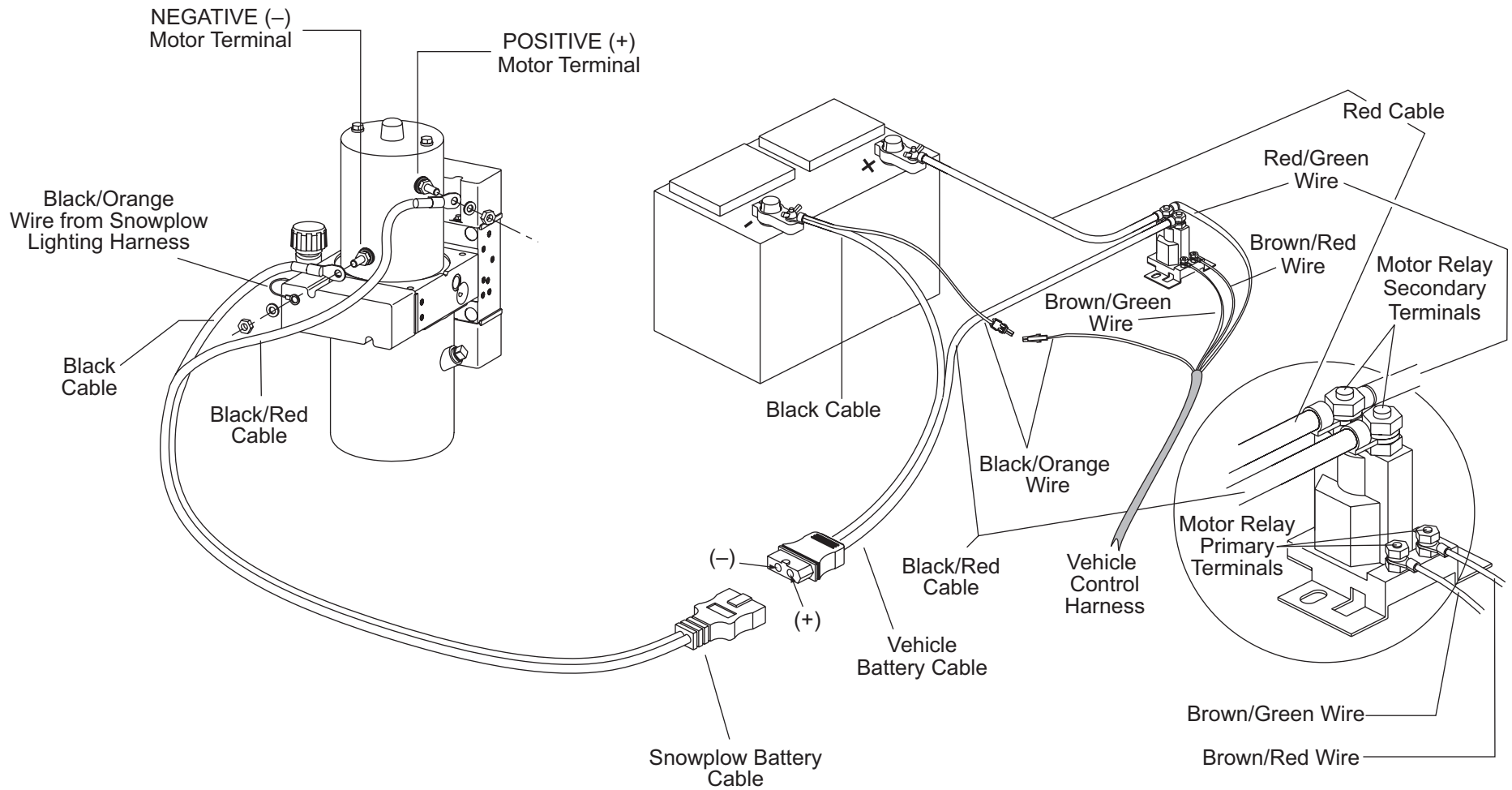



# MOTOR/CABLE TEST

## ⚠ WARNING

Keep 8' clear of the blade when it is being raised, lowered or angled. Do not stand between the vehicle and blade or directly in front of the blade. If the blade hits or drops on you, you could be seriously injured.

Refer to the Motor/Cable and Motor Relay Test Diagram.

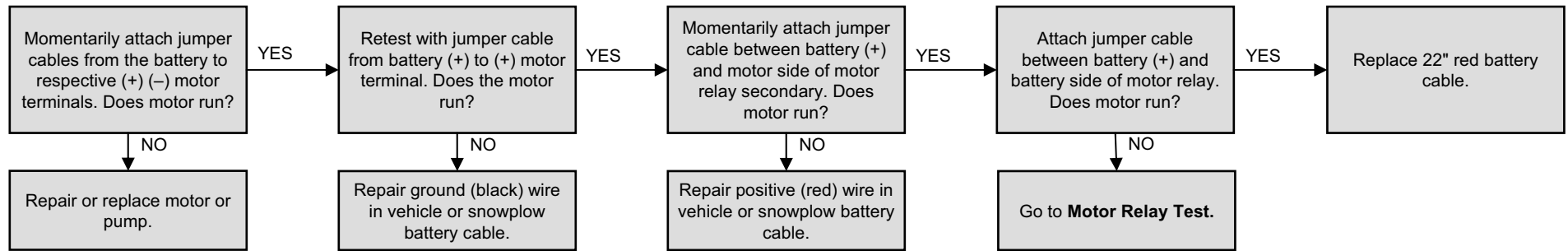

# MOTOR RELAY TEST

## ⚠ WARNING

Keep 8' clear of the blade when it is being raised, lowered or angled. Do not stand between the vehicle and blade or directly in front of the blade. If the blade hits or drops on you, you could be seriously injured.

Refer to the Motor/Cable and Motor Relay Test Diagram.

## Motor Does Not Run

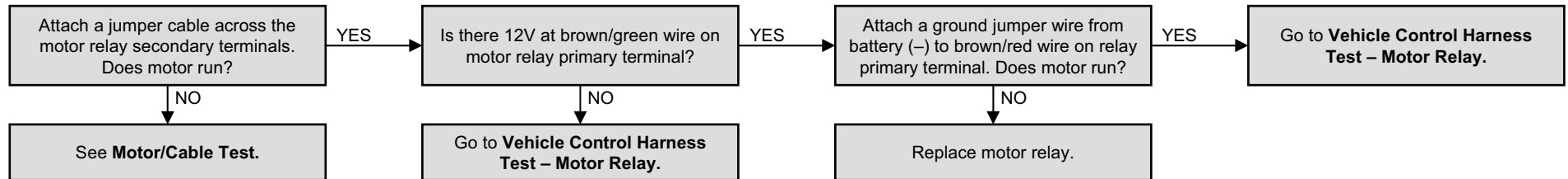

## Motor Runs Continuously

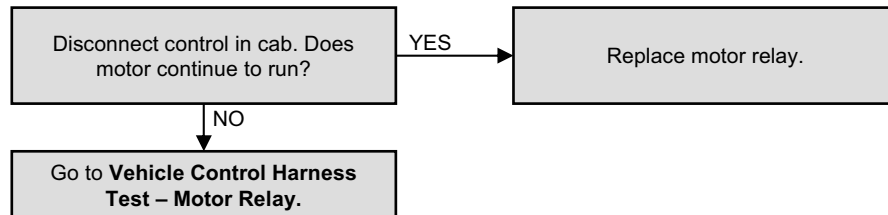

# VEHICLE CONTROL HARNESS TEST – MOTOR RELAY

## ⚠ WARNING

Keep 8' clear of the blade when it is being raised, lowered or angled. Do not stand between the vehicle and blade or directly in front of the blade. If the blade hits or drops on you, you could be seriously injured.

Perform Motor/Cable Test and Motor Relay Test first.

1. **Disconnect** the control in the cab.
2. Refer to the 14-pin Connector diagram. Test the vehicle side of the connector in the cab as follows.

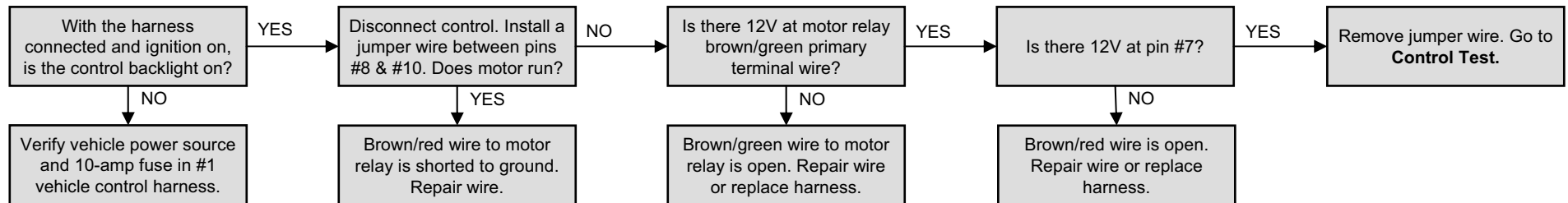
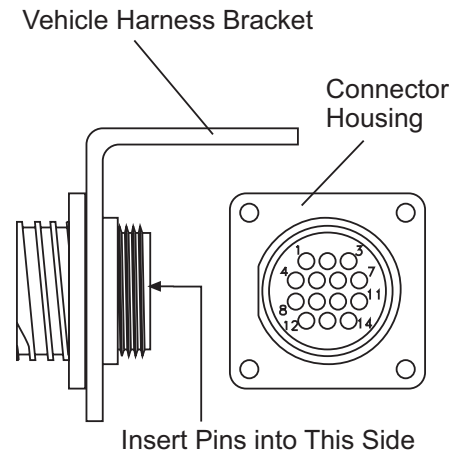

## SOLENOID COIL TESTS

---

### SOLENOID COIL ACTIVATION TEST

1. Remove the control from the 14-pin connector.
2. Remove the coil covers.
3. When prompted, check for magnetic pull across the end of each solenoid coil using a small wrench or nonmagnetized screwdriver.
4. Use the electrical schematic to locate proper wire color and valve location.

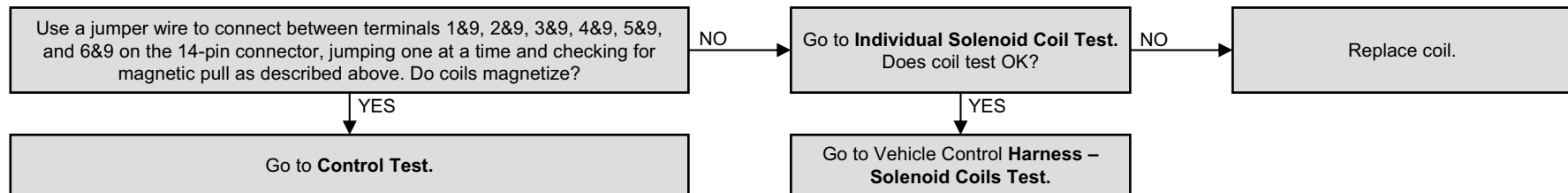

### INDIVIDUAL SOLENOID COIL TEST

1. Remove both wires from coil terminals.
  2. Attach an ohmmeter across the coil terminals.
  3. A reading of approximately 7 ohms indicates coil is OK.
  4. Attach an ohmmeter to one coil terminal and to the steel washer at the end of the coil.
  5. A reading of 0 ohms indicates that the coil has internal shorts and needs to be replaced.
- NOTE: A good coil will draw approximately 1.5 amps.**

# VEHICLE CONTROL HARNESS TEST – SOLENOID COILS

1. Perform the Solenoid Coil Activation Test first.
2. Disconnect red (+) battery cable from the motor and isolate it.
3. Connect all harness connectors at the grille.
4. Refer to the 14-pin connector diagram for pin location.

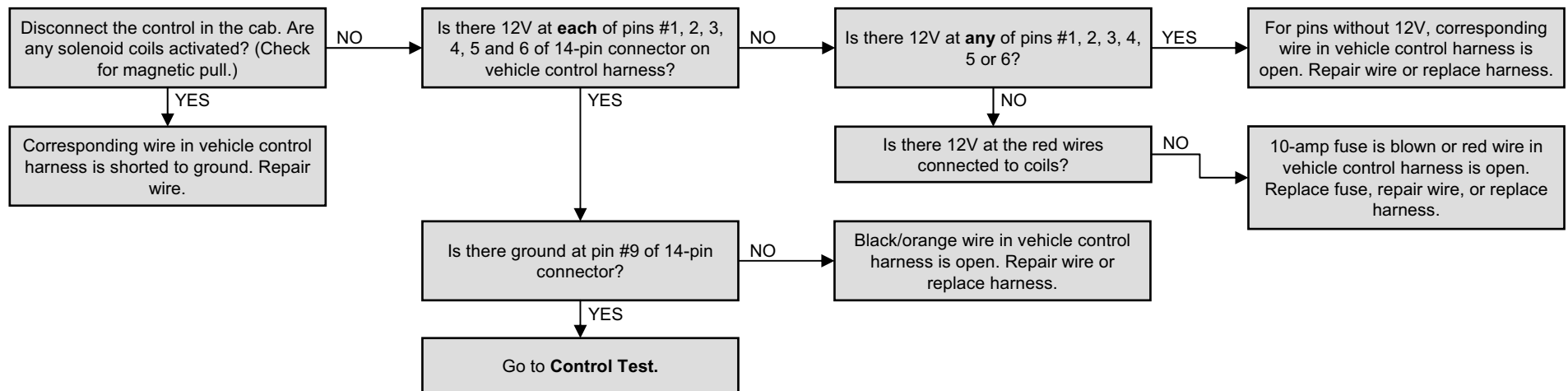
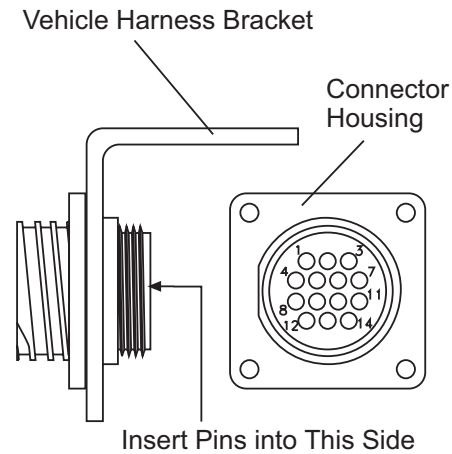

# CONTROL TEST

## ⚠ CAUTION

Printed circuit board (PCB) is subject to damage from static electricity. Follow instructions below to safely handle PCB.

### To Safely Handle PCB:

1. Place control on its side and remove top half of handle, leaving the PCB in lower half.
2. Remove PCB from housing by only touching the edges of the PCB.
3. Touch a clean finger to metal part of fuse "F2".
4. PCB is now safe to handle as long as contact with it is maintained.

### Test Procedure

1. Disconnect the control in the cab and remove to bench.
2. Test the control using the MVP® electrical tester (PN 63145). If the control is OK, go to **Vehicle Control Harness Tests**. If the control is not OK, continue.
3. Remove control handle half to access internal components.
4. Refer to diagram for fuse location.

**NOTE: Fuse F1 is for motor relay, S1, S2 and S3 solenoid coils. Fuse F2 is for S4, S5 and S6 solenoid coils. (5-pack of replacement fuses: PN 69190)**

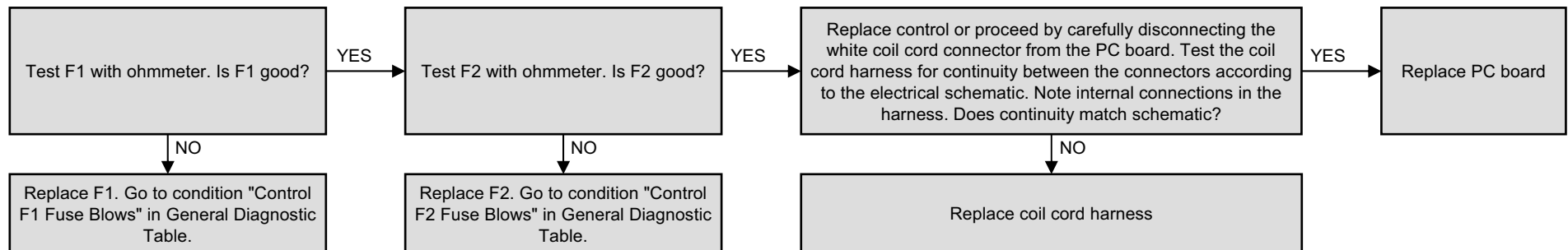
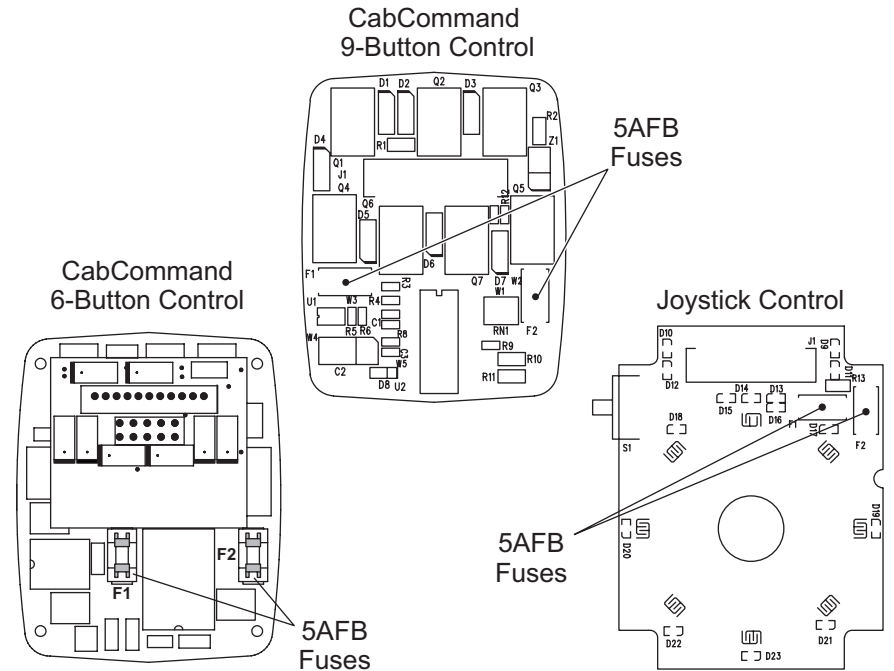

## SOLENOID CARTRIDGE VALVE INSPECTION

**NOTE: S3, the SV08-43 cartridge valve is identical to the S2 and S5 SV08-40 cartridge valves in physical appearance. These two valves function differently internally and cannot be interchanged. The only way to tell them apart is by looking for the stamping "SV08-43" or "SV08-40" on the side of the hex.**

1. Remove coils from the solenoid cartridge valves and remove the valves from manifold. Look for visible contamination or damaged seals. Check for stuck spools with a plastic, aluminum, or soft brass probe by pushing on the spring loaded internal spool from the end of the valve. The spool should move freely through its entire travel.

**NOTE: Using probe to move spool may shear contamination which was affecting spool movement.**

2. Bench test the cartridge valve by installing a coil on the stem and applying 12V and ground to coil. Watch through the side ports for internal spool travel.

If the cartridge valve spool is stuck or its travel is restricted, replace the cartridge. If the cartridge valve appears to be in good condition, clean it with parts cleaning solvent and dry with compressed air, being careful not to damage the seals. Check the spool travel again in case any internal contaminants were dislodged during cleaning. Relubricate the cartridge valve seals and O-rings. Reinstall the cartridge valve, and tighten to 10–12 ft-lb. Install the coils, and tighten retaining nuts to 4–5 ft-lb.

**NOTE: If contamination is seen in more than one component, it can be reasonably assumed that the entire system is contaminated and in order to perform a proper repair, the entire hydraulic unit must be disassembled and cleaned. The hoses and rams must also be disassembled and cleaned. The source of the contamination must be located and repaired before reassembly.**

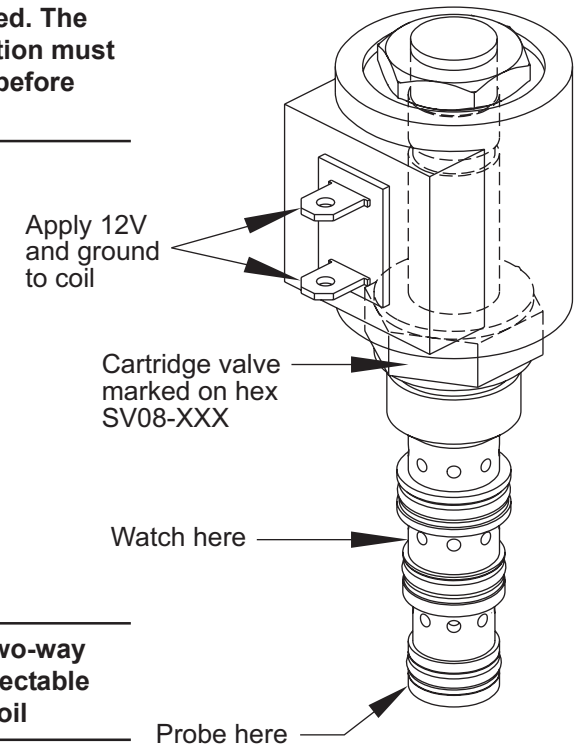

**NOTE: Spool travel for two-way valves is not visually detectable with voltage applied to coil**

# PUMP PRESSURE TEST

**NOTE: Reservoir will contain residual pressure. Loosen, then retighten, breather to release pressure before proceeding.**

1. Verify proper fluid level before beginning test.
2. Install a tee in line with the right rod end ram hydraulic hose and attach a 3000 psi pressure gauge.
3. Activate the right retract function. Read the pressure once the blade is fully retracted while continuing the right retract command.
4. Refer to Relief Valve Inspection and Adjustment section for valve location and adjustment instructions.

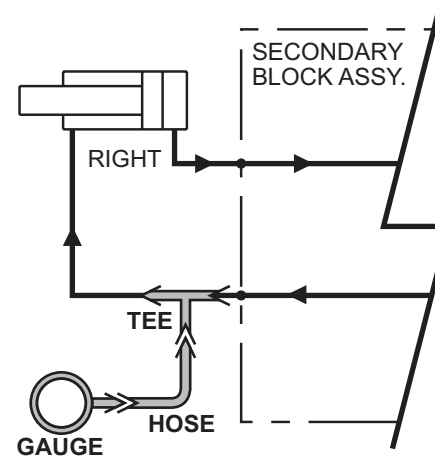
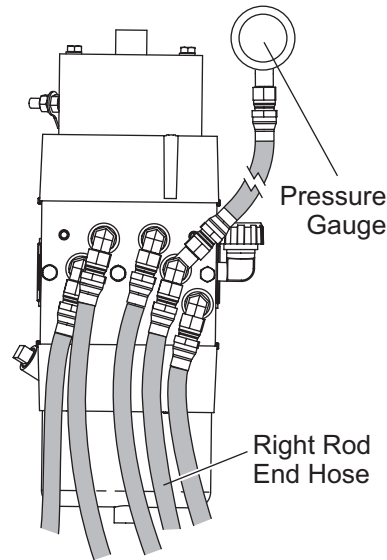

BLADE MOVEMENT		RIGHT RETRACT
MOTOR	M	ON

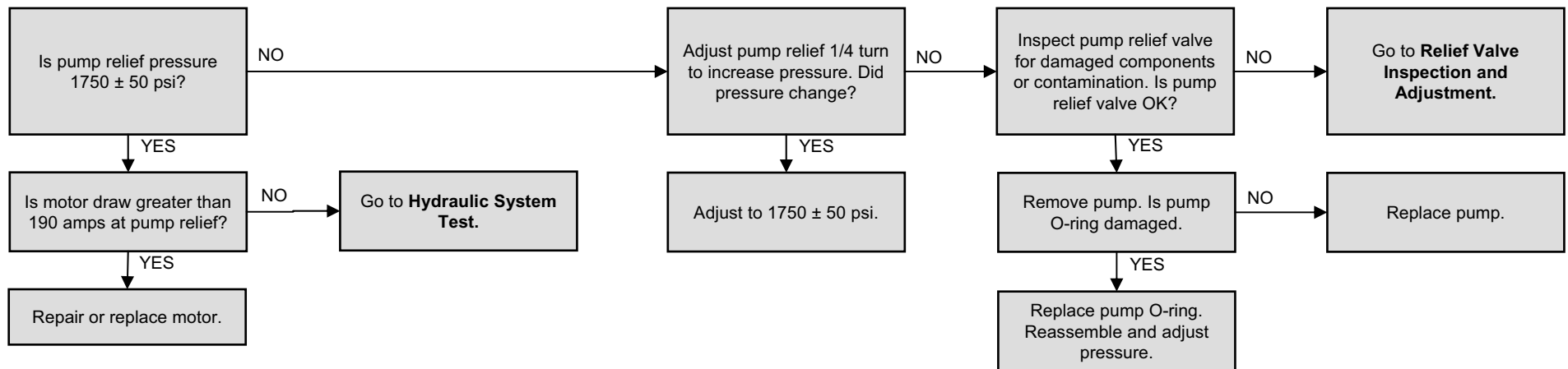



# RELIEF VALVE INSPECTION AND ADJUSTMENT

## INSPECTION

1. Remove the valve stem, ball, spacer and spring.
2. Look for broken or damaged parts, contamination or missing or damaged O-rings.

**CAUTION**  
Be careful to strike stem squarely. You can bend stem if you do not strike it squarely.

3. If parts are OK, place ball on hard wood block, hold stem seat on ball and lightly strike top of stem with a hammer. This will seat the ball and valve stem.
4. Apply a light coat of anti-seize or grease to stem threads. Lubricate O-rings with hydraulic fluid. Reassemble components into valve block.

## ADJUSTMENT

**CAUTION**  
Never operate the unit while adjusting the relief valve. Doing so will damage the relief valve O-rings.

1. Tighten the relief valve until it is fully seated (spring is compressed).

**NOTE: The three fasteners retaining the hydraulic unit to the upper lift frame must be removed to access the pump relief adjusting screw.**

2. Back off valve stem (rotate counterclockwise) the number of turns indicated in the chart.

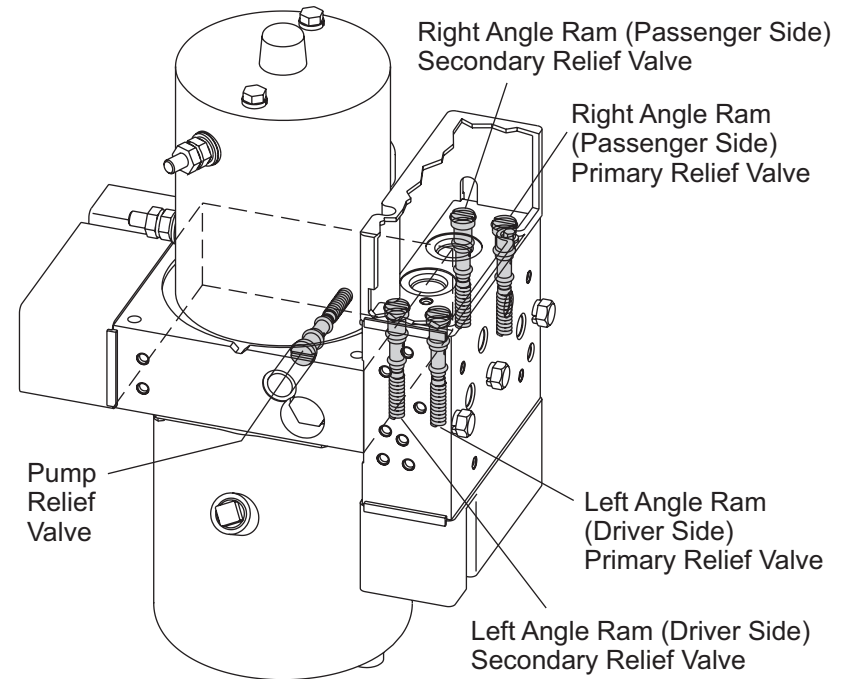
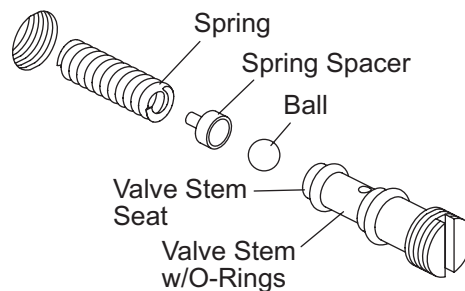

Relief Valve Settings	No. of Turns Backed Off (CCW) from Fully Seated	Approximate Relief Valve Pressure ( $\pm 50$ psi)
Pump Relief*	2-1/2 – 2-3/4	1750
Right or Left Angle Ram Primary Relief**	1-1/2 – 1-3/4	3500
Right or Left Angle Ram Secondary Relief**	1-1/4 – 1-1/2	4000

\* See Pump Pressure Test section for details.

\*\* Be certain the ram primary relief valve stem is backed out 1/4 turn farther than the secondary relief valve stem.

## PILOT-OPERATED IN-LINE CHECK VALVE INSPECTION

---

1. Remove check valve assembly from manifold block. Using long/slender needle nose pliers, remove the spool from the bore.
2. Using a probe, push on the poppet in the end of the check valve. It should move freely, then return to the closed position. If the poppet sticks open or closed or binds, replace the check valve assembly. Clean, repair or replace as necessary. Inspect the spool for signs of wear or any damage indicating it is not shifting. Look for worn or damaged O-rings and repair or replace as necessary.
3. Lubricate all O-rings, and reinstall the spool by holding the stem with the needle nose pliers and carefully inserting it fully into the bore. Install the check valve assembly, and tighten to 120–144 in-lb.

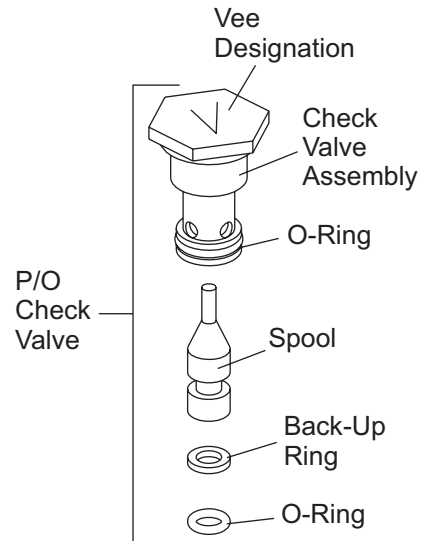





**WESTERN PRODUCTS**  
**P.O. BOX 245038**  
**MILWAUKEE, WI 53224-9538**

**DD A DIVISION OF DOUGLAS DYNAMICS, L.L.C.**

Copyright © 2005 Douglas Dynamics, L.L.C. All rights reserved. This material may not be reproduced or copied, in whole or in part, in any printed, mechanical, electronic, film or other distribution and storage media, without the written consent of Western Products. Authorization to photocopy items for internal or personal use by Western Products outlets or snowplow owner is granted.

Western Products reserves the right under its product improvement policy to change construction or design details and furnish equipment when so altered without reference to illustrations or specifications used. Western Products and the vehicle manufacturer may require and/or recommend optional equipment for snow removal. Do not exceed vehicle ratings with a snowplow. This product is manufactured under the following US patents: 4,999,935; 5,420,480; 6,145,222; 6,209,231; 6,253,470; 6,526,677; RE 35,700; CAN patent 2,060,425 and other patents pending. Western Products offers a limited warranty for all snowplows and accessories. See separately printed page for this important information. The following are registered (®) trademarks of Douglas Dynamics, L.L.C.: FloStat®, MVP®, UltraMount®, WESTERN®.

**Printed in U.S.A.**